





317L

M₂ = 150000 Nm

	i	M _{n2} [Nm]						P ₁ [kW]	P _t [kW]	n ₁ [min ⁻¹]	n _{1max} [min ⁻¹]	M _b [Nm]	
		n ₂ ·h 10 000	n ₂ ·h 25 000	n ₂ ·h 50 000	n ₂ ·h 100 000	n ₂ ·h 500 000	n ₂ ·h 1 000 000						
L1	4.09	180 000	180 000	166 000	135 000	83 000	67 000	300	85	200	300		
	5.25	170 000	153 000	141 000	130 000	80 000	65 000	300	85	200	300		
	6.23	145 000	126 000	115 000	115 000	78 000	64 000	300	85	200	300		
L2	16.9	180 000	180 000	147 000	120 000	74 000	60 000	200	55	500	800		
	22.1	179 000	177 000	144 000	117 000	72 000	59 000	200	55	500	800		
	26.6	155 000	155 000	144 000	117 000	72 000	59 000	200	55	500	800		
	28.4	170 000	153 000	141 000	130 000	80 000	65 000	200	55	500	800		
	34.1	170 000	153 000	141 000	130 000	80 000	65 000	200	55	500	800		
	40.5	145 000	126 000	115 000	115 000	78 000	64 000	200	55	500	800		
L3	58.1	180 000	180 000	147 000	120 000	74 000	60 000	130	35	1 400	2 000	3 200	6L
	69.3	180 000	174 000	141 000	115 000	71 000	58 000	130	35	1 400	2 000	3 200	6L
	89.0	180 000	179 000	145 000	118 000	73 000	59 000	130	35	1 400	2 000	2 600	6K
	106	180 000	174 000	142 000	115 000	71 000	58 000	130	35	1 400	2 000	2 100	6G
	116	179 000	177 000	144 000	117 000	72 000	59 000	130	35	1 400	2 000	1 500	6E
	138	179 000	177 000	144 000	117 000	72 000	59 000	130	35	1 400	2 000	1 500	6E
	166	155 000	155 000	144 000	117 000	72 000	59 000	130	35	1 400	2 000	1 100	6C
	179	170 000	153 000	141 000	130 000	80 000	65 000	130	35	1 400	2 000	1 100	6C
	213	170 000	153 000	141 000	130 000	80 000	65 000	130	35	1 400	2 000	850	6B
	252	145 000	126 000	115 000	115 000	78 000	63 800	115	35	1 400	2 000	850	6B
L4	310	180 000	139 000	113 000	92 000	57 000	46 000	60	18	1 800	3 800	630	5E
	360	180 000	137 000	112 000	90 000	56 000	45 000	60	18	1 800	3 800	500	5C
	449	180 000	175 000	142 000	115 000	71 000	58 000	60	18	1 800	3 800	500	5C
	493	179 000	177 000	144 000	117 000	72 000	59 000	60	18	1 800	3 800	400	5B
	552	180 000	179 000	145 000	118 000	73 000	59 000	60	18	1 800	3 800	400	5B
	619	179 000	177 000	144 000	117 000	72 000	59 000	60	18	1 800	3 800	400	5B
	719	179 000	177 000	144 000	117 000	72 000	59 000	59	18	1 800	3 800	400	5B
	792	180 000	175 000	142 000	115 000	71 000	58 000	54	18	1 800	3 800	400	5B
	904	170 000	153 000	141 000	130 000	80 000	65 000	47	18	1 800	3 800	400	5B
	1 032	179 000	177 000	144 000	117 000	72 000	59 000	41	18	1 800	3 800	400	5B
	1 134	170 000	153 000	141 000	130 000	80 000	65 000	38	18	1 800	3 800	400	5B
	1 318	170 000	153 000	141 000	130 000	80 000	65 000	32	18	1 800	3 800	400	5B
	1 595	170 000	153 000	141 000	130 000	80 000	65 000	27	18	1 800	3 800	400	5B
1 893	145 000	126 000	115 000	115 000	78 000	64 000	22	18	1 800	3 800	400	5B	

M_{2max} = 1.2 · M_{n2} (n₂ · h = 10 000)

M₂ = 150000 Nm
317R

	i	M _{n2} [Nm]						P ₁ [kW]	P _t [kW]	n ₁ [min ⁻¹]	n _{1max} [min ⁻¹]	M _b [Nm]	
		n ₂ ·h 10 000	n ₂ ·h 25 000	n ₂ ·h 50 000	n ₂ ·h 100 000	n ₂ ·h 500 000	n ₂ ·h 1 000 000						
R3 (A)	73.4	57 000	57 000	50 000	41 000	25 300	20 500	90	90	1 400	2 000	1 000	5K
	95.7	75 000	75 000	61 000	49 300	30 400	24 700	90	90	1 400	2 000	1 000	5K
	115	90 000	85 000	69 000	56 000	34 600	28 100	90	90	1 400	2 000	1 000	5K
	123	96 000	89 000	72 000	48 700	30 000	24 400	90	90	1 400	2 000	1 000	5K
	148	116 000	101 000	82 000	48 700	30 000	24 400	90	90	1 400	2 000	1 000	5K
	176	137 000	114 000	93 000	75 000	46 500	37 800	90	90	1 400	2 000	1 000	5K
R3 (B)	78.2	151 000	138 000	115 000	92 000	55 000	45 000	150	90	1 400	2 000	2 600	6K
	83.3	160 000	148 000	120 000	96 000	58 000	46 700	150	90	1 400	2 000	2 600	6K
	100	170 000	153 000	134 000	109 000	65 000	53 000	150	90	1 400	2 000	2 100	6G
	119	145 000	126 000	115 000	115 000	74 000	59 000	150	90	1 400	2 000	1 500	6E
R3 (C)	108	137 000	109 000	87 000	71 000	44 500	36 500	150	100	1 400	2 000	2 100	6G
	116	145 000	109 000	89 000	72 000	45 300	36 000	150	100	1 400	2 000	2 100	6G
	139	167 000	125 000	101 000	83 000	51 000	41 700	150	100	1 400	2 000	1 500	6E
	165	145 000	126 000	114 000	93 000	57 000	47 600	142	100	1 400	2 000	1 100	6C
R4	220	99 000	88 000	71 000	58 000	35 800	29 100	90	50	1 800	3 800	500	5C
	262	115 000	100 000	81 000	66 000	40 500	32 900	90	50	1 800	3 800	500	5C
	336	145 000	119 000	96 000	78 000	48 300	39 200	90	50	1 800	3 800	500	5C
	399	172 000	134 000	109 000	88 000	54 000	44 200	90	50	1 800	3 800	500	5C
	438	179 000	143 000	116 000	94 000	58 000	47 200	90	50	1 800	3 800	500	5C
	520	179 000	161 000	131 000	106 000	66 000	53 000	82	50	1 800	3 800	400	5B
	626	155 000	155 000	144 000	117 000	72 000	59 000	68	50	1 800	3 800	400	5B
	677	170 000	153 000	141 000	48 700	30 000	24 400	63	50	1 800	3 800	400	5B
	803	170 000	153 000	141 000	48 700	30 000	24 400	53	50	1 800	3 800	400	5B
	953	145 000	126 000	115 000	115 000	78 000	64 000	45	50	1 800	3 800	400	5B

$$M_{2max} = 1.2 \cdot M_{n2} \quad (n_2 \cdot h = 10\,000)$$

Nota: i contrassegni (A) (B) (C) sulla stessa grandezza, indicano riduzioni angolari di dimensioni differenti: vedere le pagine dimensionali.

Note: Letters (A) (B) (C) near size indication identify different angle reduction dimensions. See pages relevant to dimensions.

Hinweis: Die Kennzeichnungen (A) (B) (C) an der gleichen Baugröße weisen auf die Winkelreduzierung in unterschiedlichen Maßen hin: siehe Seiten mit Maßtabellen.

Remarque : les indications (A) (B) (C) sur la même taille indique des réductions angulaires de dimensions différentes. Se reporter aux pages des dimensions.

317L

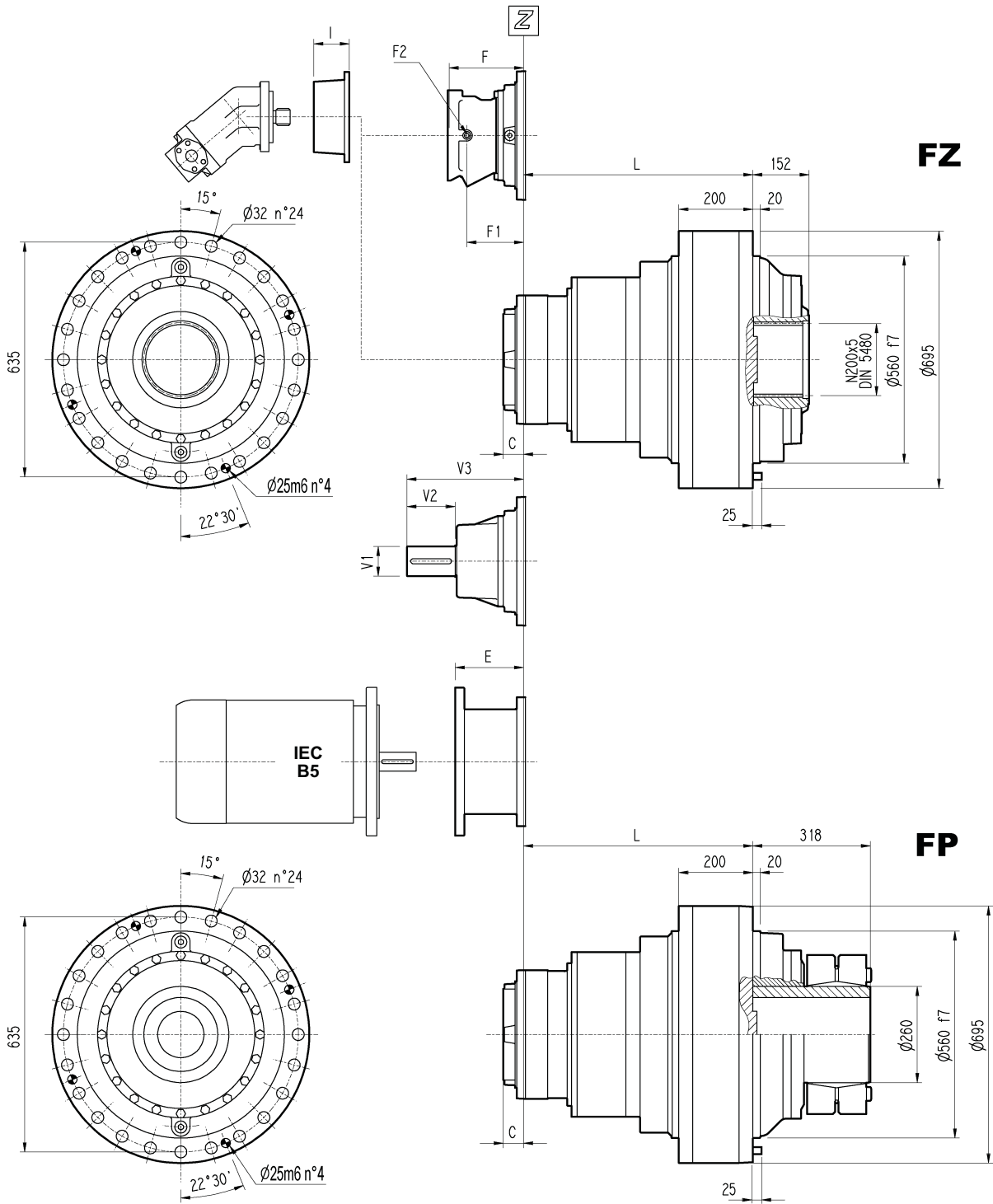

VERSIONE FP/FP VERSION VERSION FP/VERSION FP	COPPIA MAX. TRASSMISS./MAX. TRANSMISS. TORQUE MAX. ÜBERTR. MOMENT/COUPLE MAX. TRANSMISSIBLE	216 000 Nm
---	--	-------------------

	L				Kg				C	Entrata Input Antrieb Entrée	I	F	F1	F2	Tipo Type Typ	Entrata Input Antrieb Entrée	Kg
	HZ HC	PC PZ	FZ	FP	HZ HC	PC PZ	FZ	FP									
317 L1	163	315	163	163	800	950	750	800	181	F	191						
317 L2	472	624	472	472	930	1 080	880	930	75	D							
317 L3	621	773	621	621	990	1 140	940	990	51	B		201	153	1/4 G	6	B	28
317 L4	710	862	710	710	1 002	1 152	952	1 002	37	A		145	95	1/4 G	5	A	16

	V1	V2	V3	Kg	V1	V2	V3	Kg	E								
									IEC 132	IEC 160	IEC 180	IEC 200	IEC 225	IEC 250			
317 L1																	
317 L2	80	130	343	35													
317 L3	80	130	315	35	60	105	313	28					195	186	216	215	
317 L4	48	82	239	15									114	144	144	174	

317R

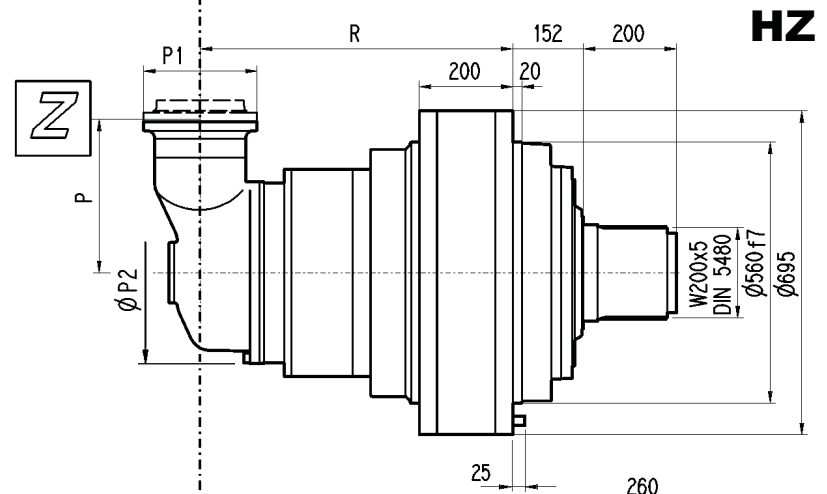
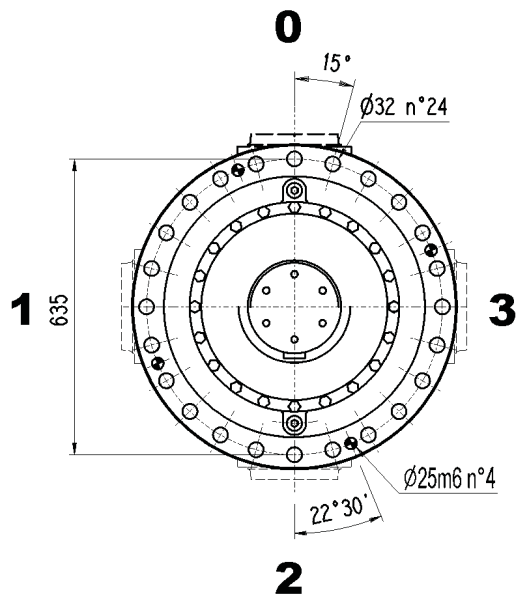
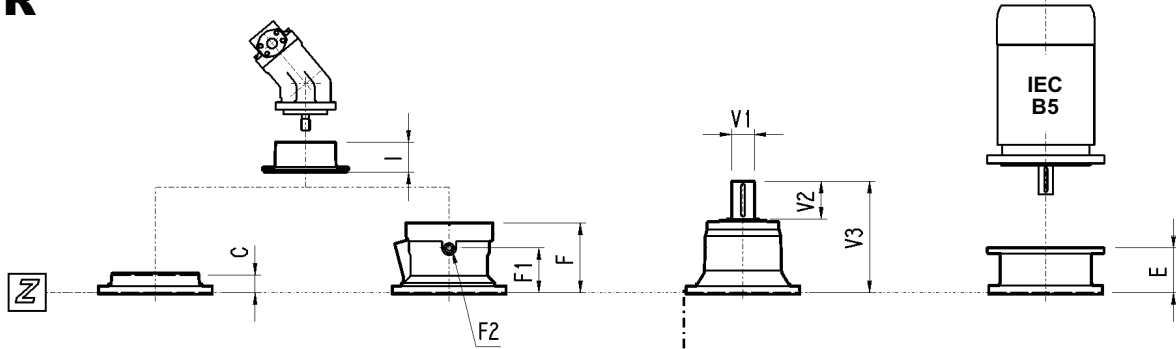

HZ

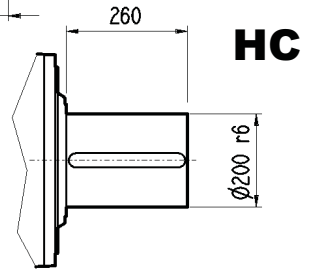

HC

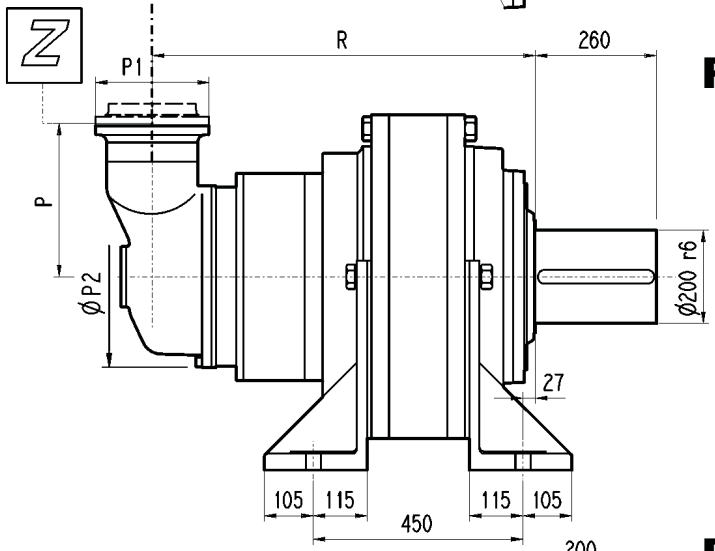
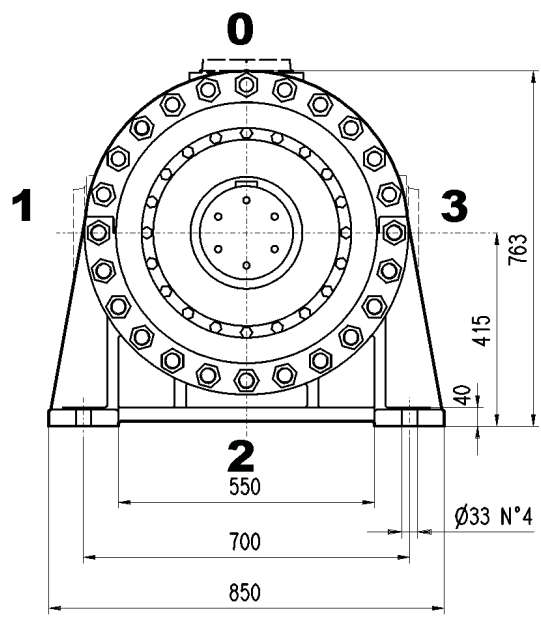

PC

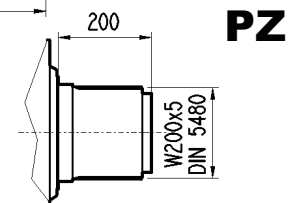

PZ

317R

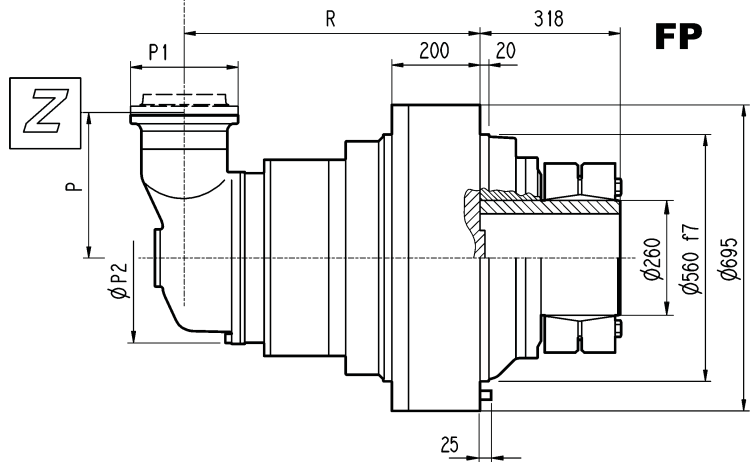
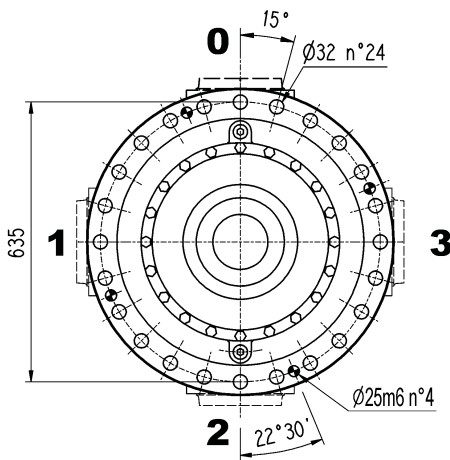
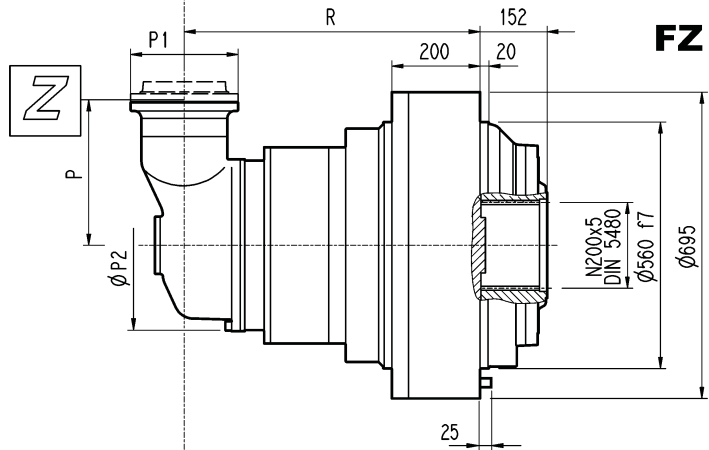
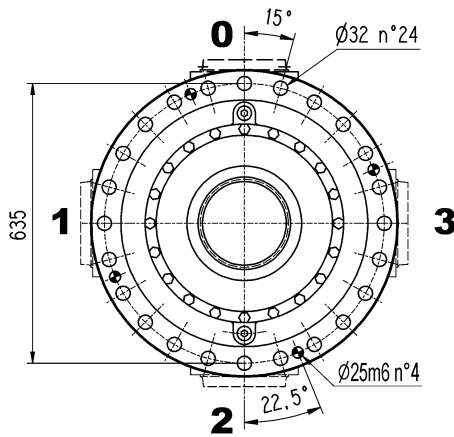
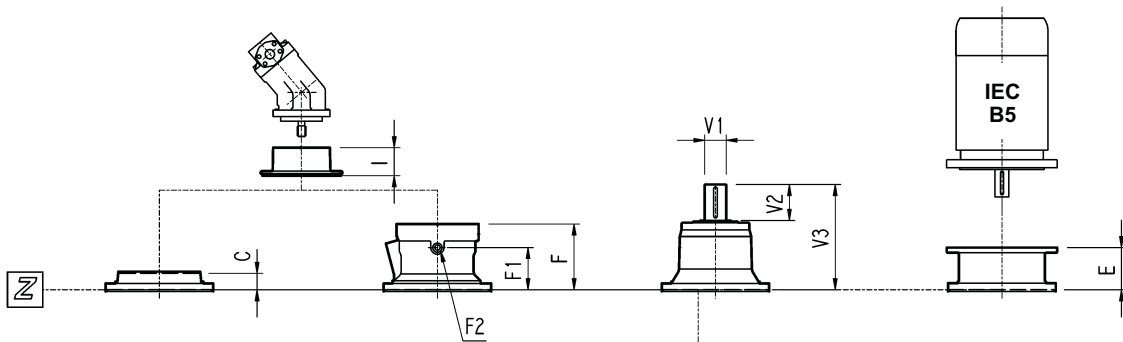

VERSIONE FP FP VERSION VERSION FP VERSION FP	COPPIA MAX. TRASMISSIBILE MAX. TRANSMISSIBLE TORQUE MAX. ÜBERTR. MOMENT COUPLE MAX. TRANSMISSIBLE	216 000 Nm
---	--	-------------------

	R				P	P1	P2	Kg				C	Entrata Input Antrieb Entrée	I	F	F1	F2	Tipo Type Typ Type	Entrata Input Antrieb Entrée	Kg
	HZ HC	PC PZ	FZ	FP				HZ HC	PC PZ	FZ	FP									
317 R3 (B)	701	853	701	701	345	262	400	1060	1210	1010	1060	45	B	191	195	147	1/4 G	6	B	28
317 R3 (C)	701	853	701	701	390	262	480	1070	1220	1020	1070	45	B		195	147	1/4 G	6	B	28
317 R3 (A)	701	853	701	701	330	245	390	1040	1190	990	1040	37	A		145	95	1/4 G	5	A	16
317 R4	740	892	740	740	225	245	345	1040	1190	990	1040	37	A	105	65	1/4 G	4	A	10	

	V1	V2	V3	Kg	V1	V2	V3	Kg	E										
									IEC 71	IEC 80	IEC 90	IEC 100	IEC 112	IEC 132	IEC 160	IEC 180	IEC 200	IEC 225	IEC 250
317 R3 (B)	60	105	307	23												152	182	212	193
317 R3 (C)	60	105	307	23												152	182	212	193
317 R3 (A)	48	82	239	15										114	144	144	174		
317 R4	48	82	239	15										114	144	144	174		

317L - 317R

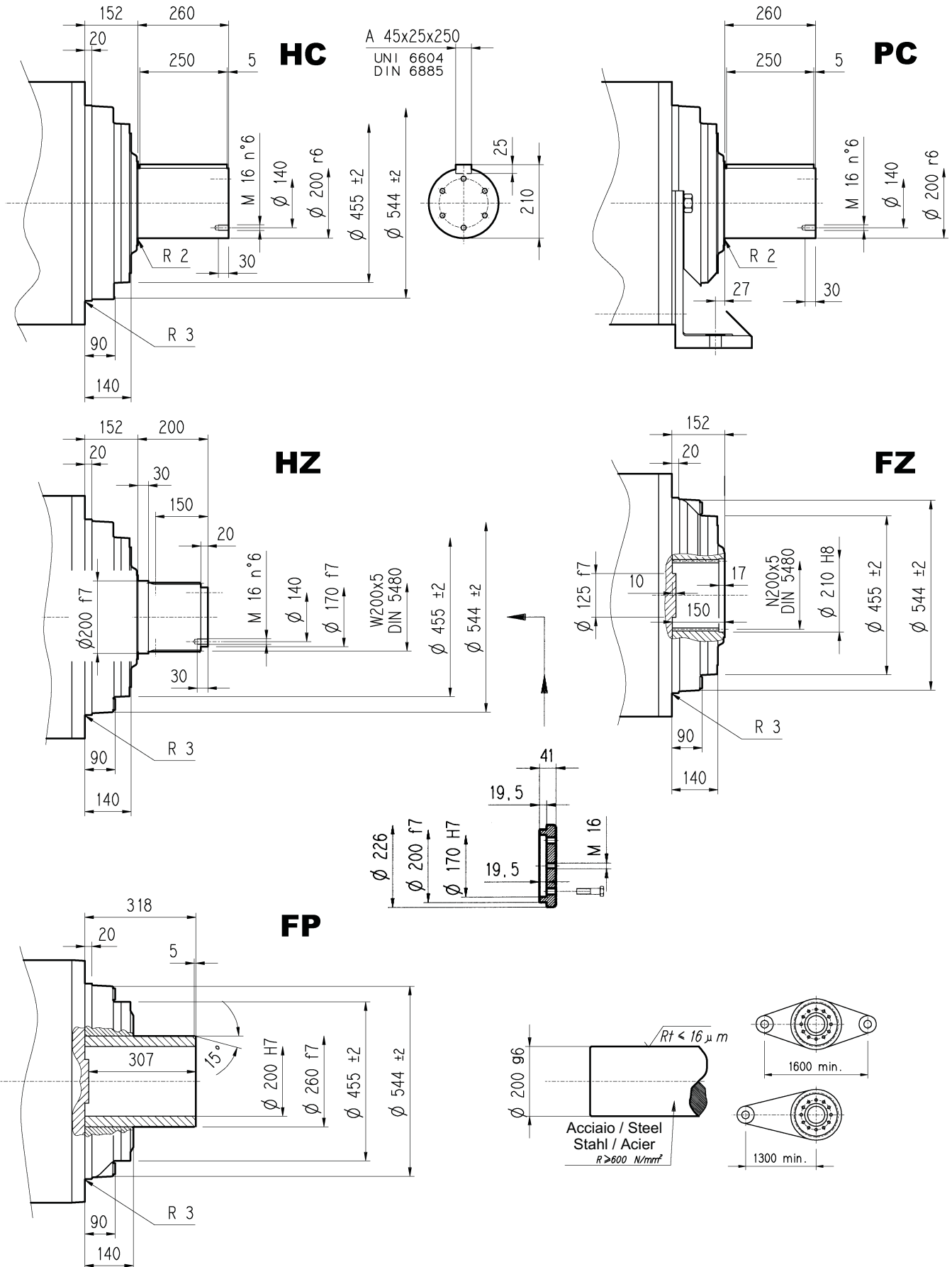

VERSIONE FP	COPPIA MAX. TRASMISSIBILE	216 000 Nm
FP VERSION	MAX. TRANSMISSIBLE TORQUE	
VERSION FP	MAX. ÜBERTR. MOMENT	
VERSION FP	COUPLE MAX. TRANSMISSIBLE	

Flangia / Flange
Flansch / Brides

317L - 317R

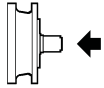

WOA

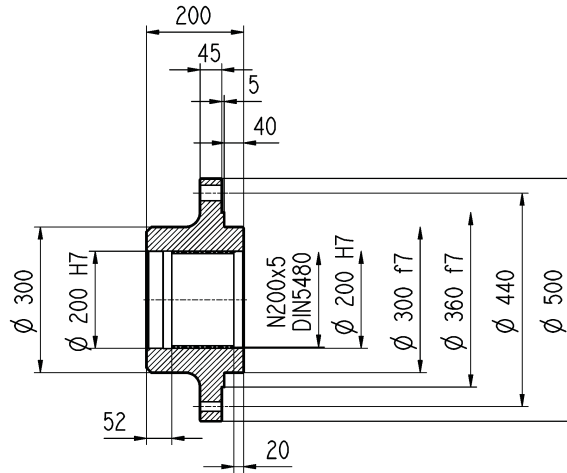
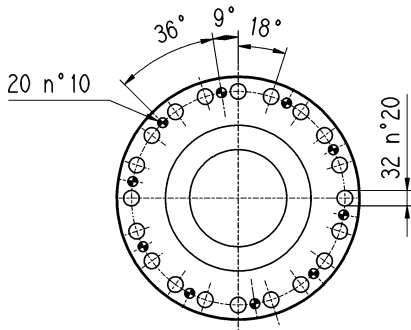

Materiale : Acciaio C40
Material : Steel C40
Material : Stahl C40
Màterial : Acier C40

Manicotti lisci / Sleeve couplings
Naben / Manchons lisses a cannelure interieure

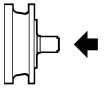

MOA

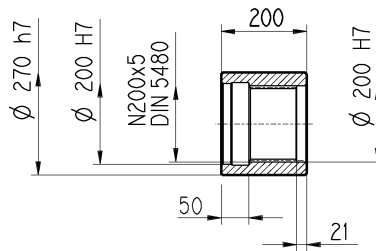

Materiale : Acciaio 16CrNi4
Material : Steel 16CrNi4
Material : Stahl 16CrNi4
Màterial : Acier 16CrNi4

Giunto ad attrito / Shrink disc
Schrumpfscheibe / Frette de serrage

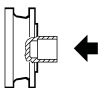

GOA

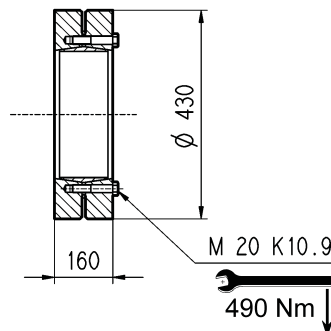

317L - 317R

Alberi veloci / Input shaft
Antriebswellen / Arbres d'entrée

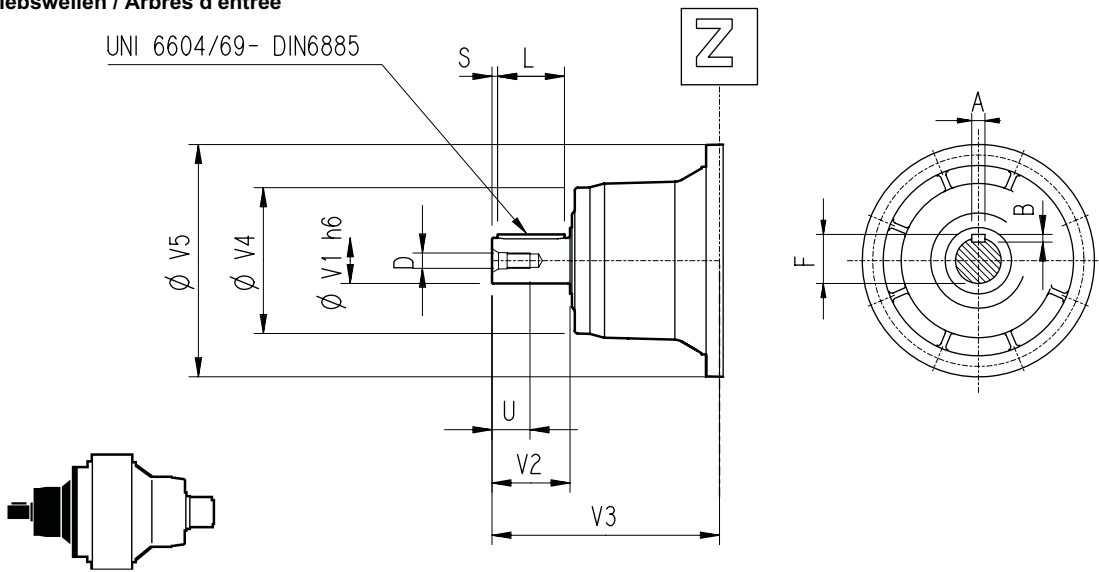

	CODE	V1	V2	V3	V4	V5	A	B	F	L	S	D	U
317 L2	V11B	80	130	343	200	428	22	14	85	110	10	M16	36
317 L3	V07B	80	130	315	200	345	22	14	85	110	10	M16	36
	V07A	60	105	313	155	345	18	11	64	90	7.5	M16	36
317 L4	V05B	48	82	239	155	245	14	9	51.5	70	6	M16	36
317 R3 (A)-R4	V05B	48	82	239	155	245	14	9	51.5	70	6	M16	36
317 R3 (B) (C)	V06B	60	105	307	155	292	18	11	64	90	7.5	M16	36

Dimensioni d'entrata senza predisposizione motore
Input dimension without motor adaptor
Maße für den Antrieb ohne Motoradapter
Dimensions d'entrée sans prédisposition moteur

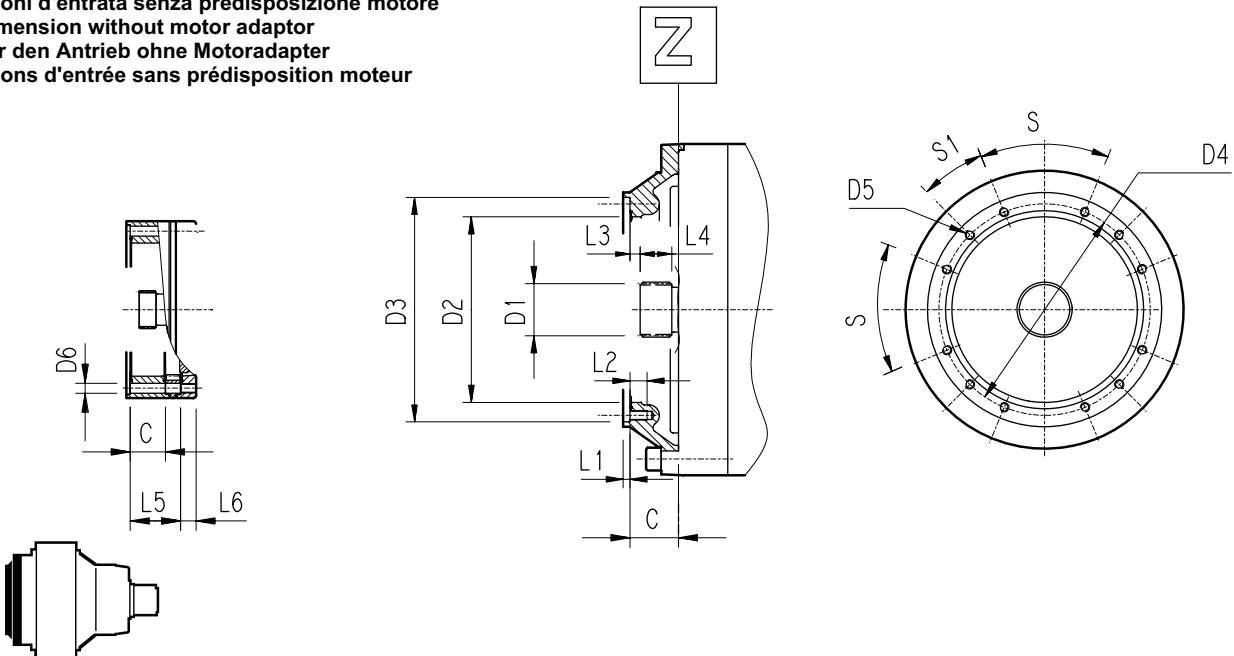

	C	D1	D2	D3	D4	D5	D6	L1	L2	L3	L4	L5	L6	S	S1	Entrata Input Antrieb Entrée
317 L1	181	120x3 DIN 5480	365	390 f7	415	M16 n°18	/	4	30	3	65	/	/	20°	20°	F
317 L2	75	80x74 DIN 5482	270	335 H7	314	M16 n°8	/	5	30	9.5	40	/	/	60°	30°	D
317 L3	51	58x53 DIN 5482	195	236 H7	222	M10 n°12	/	4	18	11	22	/	/	45°	22.5°	B
317 L4	37	40x36 DIN 5482	140	178 H7	165	M10 n°8	0	4	18	9	18	0	0	45°	45°	A
317 R2-R3 (A)-R4	37	40x36 DIN 5482	140	178 H7	165	M10 n°8	11	4	18	9	18	0	0	45°	45°	A
317 R3 (B) (C)	45	58x53 DIN 5482	195	236 H7	222	M10 n°12	/	4	18	11	22	/	/	45°	22.5°	B

317L - 317R

Carichi radiali ed assiali ammissibili sull'albero lento per un valore di $Fh_2 : n_2 \cdot h = 10\ 000$

Permissible radial and axial loads on output shaft with $Fh_2 : n_2 \cdot h = 10\ 000$

An der Ausgangswelle zulässige Radiallasten und Axialkräfte für einen Wert von $Fh_2 : n_2 \cdot h = 10\ 000$

Charges radiales et axiales admises sur l'arbre lent pour une valeur de $Fh_2 : n_2 \cdot h = 10\ 000$

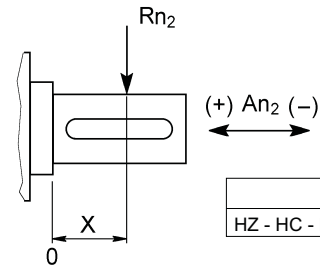
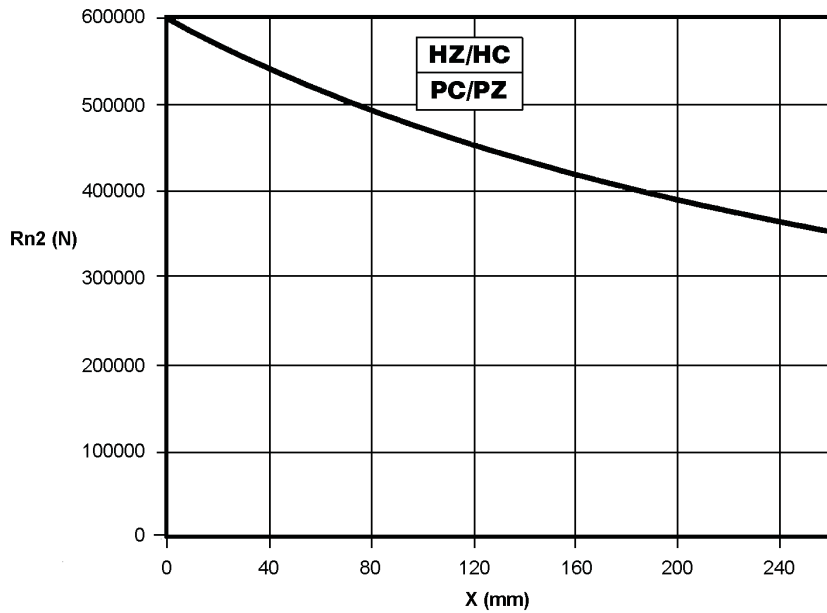

	An ₂ (+)	An ₂ (-)
HZ - HC - PC - PZ	360 000	300 000

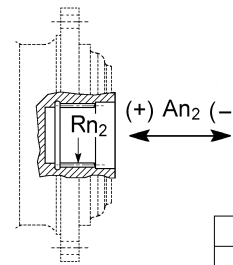

	Rn ₂	An ₂ (+/-)
FZ	150 000	150 000

Fattore fh ₂ correttivo per carichi sugli alberi Load corrective factor fh ₂ on shafts Korrektionsfaktor fh ₂ für wellenbelastungen Facteur de correction fh ₂ pour charges sur les arbres	Fh ₂ = n ₂ · h						
		10 000	25 000	50 000	100 000	500 000	1 000 000
fh ₂	FZ	1	0.74	0.58	0.46	0.27	0.21
	HZ - HC - PC - PZ	1	0.76	0.61	0.50	0.31	0.25

Carichi radiali ammissibili sull'albero veloce per un valore di $Fh_1 : n_1 \cdot h = 250\ 000$

Permissible radial loads on input shaft with $Fh_1 : n_1 \cdot h = 250\ 000$

An der Antriebswelle zulässige Radiallasten für einen Wert von $Fh_1 : n_1 \cdot h = 250\ 000$

Charges radiales admises sur l'arbre d'entrée pour une valeur de $Fh_1 : n_1 \cdot h = 250\ 000$

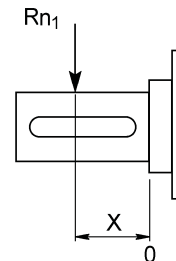
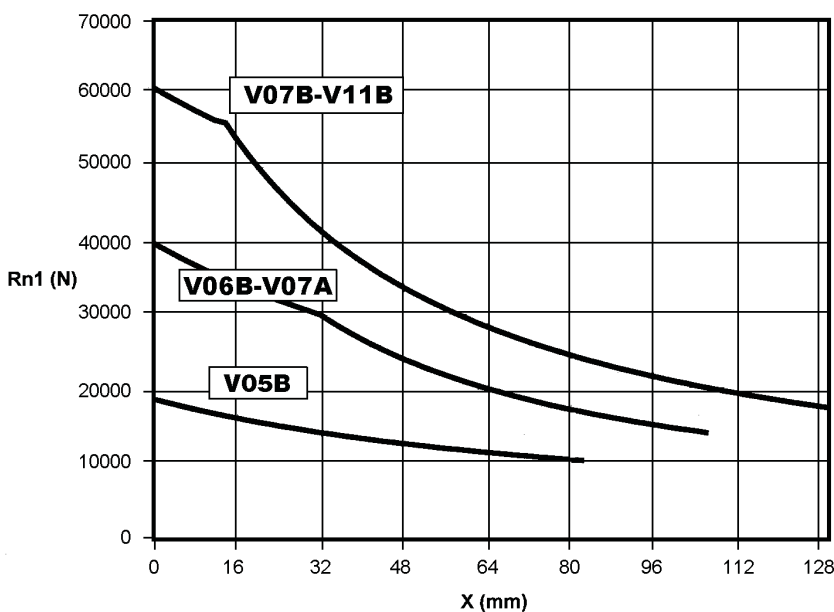

Fattore fh ₁ correttivo per carichi sugli alberi Load corrective factor fh ₁ on shafts Korrektionsfaktor fh ₁ für wellenbelastungen Facteur de correction fh ₁ pour charges sur les arbres	Fh ₁ = n ₁ · h						
		250 000	500 000	1 000 000	2 000 000	5 000 000	10 000 000
fh ₁	1	0.79	0.63	0.50	0.37	0.29	