





**315L**

**M<sub>2</sub> = 80000 Nm**

	i	M <sub>n2</sub> [Nm]						P <sub>1</sub> [kW]	P <sub>t</sub> [kW]	n <sub>1</sub> [min <sup>-1</sup> ]	n <sub>1max</sub> [min <sup>-1</sup> ]	M <sub>b</sub> [Nm]	
		n <sub>2</sub> ·h 10 000	n <sub>2</sub> ·h 25 000	n <sub>2</sub> ·h 50 000	n <sub>2</sub> ·h 100 000	n <sub>2</sub> ·h 500 000	n <sub>2</sub> ·h 1 000 000						
<b>L1</b>	4.09	105 000	100 000	97 000	85 000	53 000	42 800	260	60	350	500		
	5.25	99 000	87 000	79 000	78 000	49 000	39 700	260	60	350	500		
	6.23	80 000	70 000	65 000	65 000	41 000	33 300	260	60	350	500		
<b>L2</b>	16.7	105 000	100 000	97 000	79 000	48 700	39 600	180	45	750	1 000		
	21.5	105 000	100 000	97 000	83 000	51 000	41 700	180	45	750	1 000		
	25.5	105 000	100 000	97 000	78 000	48 400	39 400	180	45	750	1 000		
	27.6	99 000	87 000	79 000	78 000	48 800	39 700	180	45	750	1 000		
	32.7	99 000	87 000	79 000	78 000	48 800	39 700	180	45	750	1 000		
	38.8	80 000	70 000	65 000	65 000	41 000	33 300	157	45	750	1 000		
<b>L3</b>	57.4	105 000	100 000	97 000	79 000	48 700	39 600	100	30	1 500	2 500	2 600	6K
	68.5	105 000	100 000	97 000	79 000	48 700	39 600	100	30	1 500	2 500	2 100	6G
	87.9	105 000	100 000	97 000	79 000	48 700	39 600	100	30	1 500	2 500	1 500	6E
	104	105 000	100 000	97 000	79 000	48 700	39 600	100	30	1 500	2 500	1 100	6C
	134	105 000	100 000	97 000	83 000	51 000	41 700	100	30	1 500	2 500	850	6B
	159	105 000	100 000	97 000	78 000	48 400	39 400	100	30	1 500	2 500	850	6B
	172	99 000	87 000	79 000	78 000	48 800	39 700	100	30	1 500	2 500	850	6B
	204	99 000	87 000	79 000	78 000	48 800	39 700	87	30	1 500	2 500	850	6B
	242	80 000	70 000	65 000	65 000	41 000	33 300	61	30	1 500	2 500	850	6B
<b>L4</b>	291	105 000	100 000	97 000	79 000	48 700	39 600	60	18	1 800	3 800	400	5B
	356	105 000	100 000	97 000	79 000	48 700	39 600	60	18	1 800	3 800	400	5B
	424	105 000	100 000	97 000	79 000	48 700	39 600	59	18	1 800	3 800	400	5B
	469	105 000	100 000	97 000	79 000	48 700	39 600	53	18	1 800	3 800	400	5B
	513	105 000	100 000	97 000	79 000	48 700	39 600	48	18	1 800	3 800	400	5B
	569	105 000	100 000	97 000	83 000	51 000	41 700	44	18	1 800	3 800	400	5B
	647	105 000	100 000	97 000	79 000	48 700	39 600	38	18	1 800	3 800	400	5B
	714	105 000	100 000	97 000	83 000	51 000	41 700	35	18	1 800	3 800	400	5B
	830	105 000	100 000	97 000	83 000	51 000	41 700	30	18	1 800	3 800	400	5B
	916	99 000	87 000	79 000	78 000	48 800	39 700	27	18	1 800	3 800	400	5B
	1 004	105 000	100 000	97 000	83 000	51 000	41 700	25	18	1 800	3 800	400	5B
	1 087	99 000	87 000	79 000	78 000	48 800	39 700	23	18	1 800	3 800	400	5B
	1 264	99 000	87 000	79 000	78 000	48 800	39 700	19.7	18	1 800	3 800	400	5B
	1 500	80 000	70 000	65 000	65 000	41 000	33 300	16.6	18	1 800	3 800	400	5B
1 814	80 000	70 000	65 000	65 000	41 000	33 300	13.7	18	1 800	3 800	400	5B	

**M<sub>2max</sub> = 1.2 · M<sub>n2</sub>** (n<sub>2</sub> · h = 10 000)

**M<sub>2</sub> = 80000 Nm**
**315R**

	i	M <sub>n2</sub> [Nm]						P <sub>1</sub> [kW]	P <sub>t</sub> [kW]	n <sub>1</sub> [min <sup>-1</sup> ]	n <sub>1max</sub> [min <sup>-1</sup> ]	M <sub>b</sub> [Nm]	
		n <sub>2</sub> ·h 10 000	n <sub>2</sub> ·h 25 000	n <sub>2</sub> ·h 50 000	n <sub>2</sub> ·h 100 000	n <sub>2</sub> ·h 500 000	n <sub>2</sub> ·h 1 000 000						
<b>R3 (A)</b>	72.5	57 000	57 000	50 000	40 600	25 100	20 300	135	75	1 500	2 500	1 000	5K
	93.1	73 000	73 000	60 000	48 300	29 800	24 200	135	75	1 500	2 500	1 000	5K
	110	86 000	83 000	67 000	55 000	33 600	27 300	135	75	1 500	2 500	1 000	5K
	119	93 000	87 000	71 000	58 000	35 500	28 900	135	75	1 500	2 500	1 000	5K
	142	99 000	87 000	79 000	65 000	40 000	32 500	119	75	1 500	2 500	800	5G
	168	80 000	70 000	65 000	65 000	41 000	33 300	83	75	1 500	2 500	500	5C
<b>R3 (B)</b>	49.2	102 000	94 000	82 000	66 000	39 300	32 300	150	75	1 500	2 500	2600	6K
	63.1	105 000	100 000	97 000	80 000	48 500	38 400	150	75	1 500	2 500	2100	6G
	74.9	105 000	100 000	97 000	78 000	48 800	39 400	150	75	1 500	2 500	2100	6G
	81.0	99 000	87 000	79 000	78 000	48 800	39 700	150	75	1 500	2 500	1500	6E
	96.2	99 000	87 000	79 000	78 000	48 800	39 700	150	75	1 500	2 500	1500	6E
	114	80 000	70 000	65 000	65 000	41 000	33 300	118	75	1 500	2 500	850	6B
<b>R3 (C)</b>	68.0	99 000	75 000	61 000	49 600	30 700	25 200	150	90	1 500	2 500	2100	6G
	87.3	105 000	88 000	73 000	59 000	37 400	30 300	150	90	1 500	2 500	1500	6E
	104	105 000	100 000	77 000	67 000	40 800	33 600	150	90	1 500	2 500	1500	6E
	112	99 000	87 000	79 000	70 000	44 100	36 300	148	90	1 500	2 500	1100	6C
	133	99 000	87 000	79 000	78 000	48 800	39 700	127	90	1 500	2 500	1100	6C
	158	80 000	70 000	65 000	65 000	41 000	33 300	88	90	1 500	2 500	850	6B
<b>R4</b>	217	98 000	87 000	71 000	58 000	35 500	28 900	90	40	1 800	3 800	500	5C
	259	105 000	99 000	80 000	65 000	40 200	32 600	90	40	1 800	3 800	500	5C
	332	105 000	100 000	95 000	78 000	47 900	38 900	75	40	1 800	3 800	400	5B
	394	105 000	100 000	97 000	79 000	48 700	39 600	63	40	1 800	3 800	400	5B
	506	105 000	100 000	97 000	83 000	51 000	41 700	49	40	1 800	3 800	400	5B
	600	105 000	100 000	97 000	78 000	48 400	39 300	41	40	1 800	3 800	400	5B
	649	99 000	87 000	79 000	78 000	48 800	39 700	38	40	1 800	3 800	400	5B
	770	99 000	87 000	79 000	78 000	48 800	39 700	32	40	1 800	3 800	400	5B
	914	80 000	70 000	65 000	65 000	41 000	33 300	26	40	1 800	3 800	400	5B

$$M_{2max} = 1.2 \cdot M_{n2} \quad (n_2 \cdot h = 10\,000)$$

Nota: i contrassegni (A) (B) (C) sulla stessa grandezza, indicano riduzioni angolari di dimensioni differenti: vedere le pagine dimensionali.

Note: Letters (A) (B) (C) near size indication identify different angle reduction dimensions. See pages relevant to dimensions.

Hinweis: Die Kennzeichnungen (A) (B) (C) an der gleichen Baugröße weisen auf die Winkelreduzierung in unterschiedlichen Maßen hin: siehe Seiten mit Maßtabellen.

Remarque : les indications (A) (B) (C) sur la même taille indique des réductions angulaires de dimensions différentes. Se reporter aux pages des dimensions.

**315L**

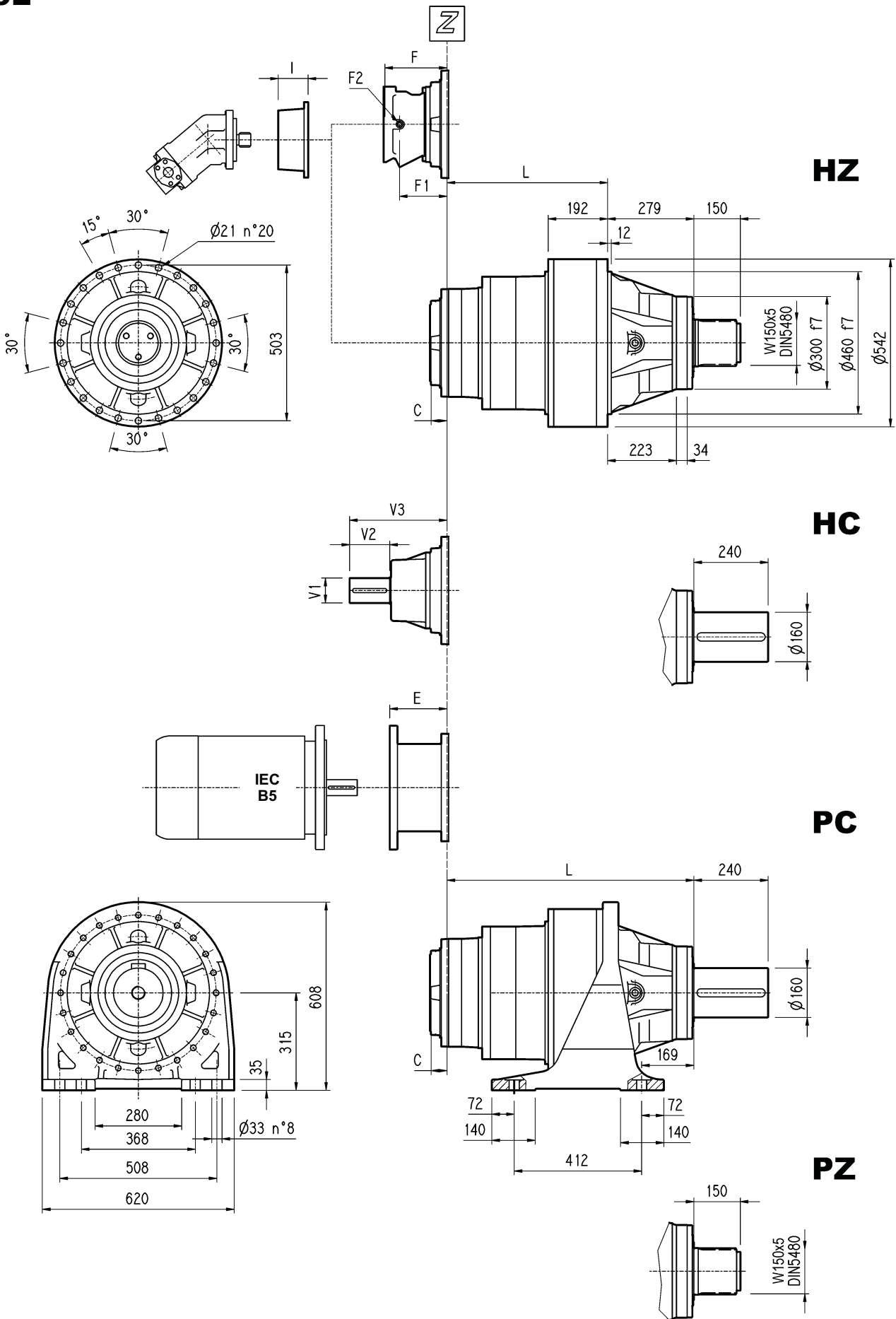

**315L**

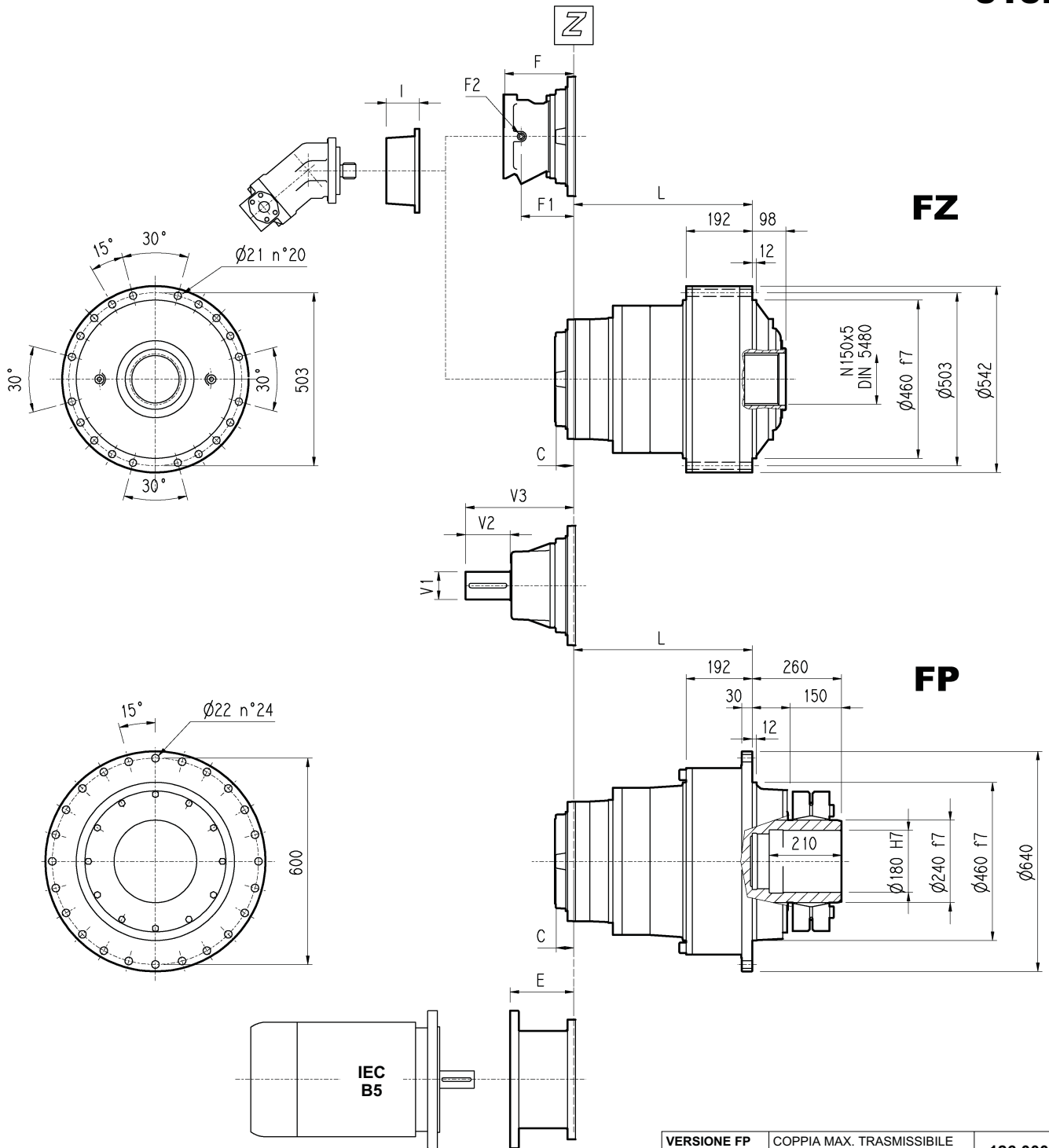

VERSIONE FP	COPPIA MAX. TRASMISSIBILE	<b>126 000</b> Nm
FP VERSION	MAX. TRASMISSIBILE TORQUE	
VERSION FP	MAX. ÜBERTR. MOMENT	
VERSION FP	COUPLE MAX. TRASMISSIBILE	

	L				Kg				C	Entrata Input Antrieb Entrée	I	F			Tipo Type Typ Type	Entrata Input Antrieb Entrée	Kg
	HZ HC	PC PZ	FZ	FP	HZ HC	PC PZ	FZ	FP				F	F1	F2			
315 L1	174	453	174	174	370	500	280	330	116	E	191						
315 L2	386	665	386	386	455	585	365	415	81	D		232	185	1/4 G	6	B	35
315 L3	519	798	519	519	500	630	410	460	51	B		201	153	1/4 G	6	B	28
315 L4	608	887	608	608	512	642	422	472	37	A		145	95	1/4 G	5	A	16

	V1	V2	V3	Kg	E											
					V1	V2	V3	Kg	IEC 132	IEC 160	IEC 180	IEC 200	IEC 225	IEC 250		
315 L1																
315 L2	80	130	348	35												
315 L3	80	130	315	35	60	105	313	28					195	186	216	215
315 L4	48	82	239	15									114	144	144	174



**315R**

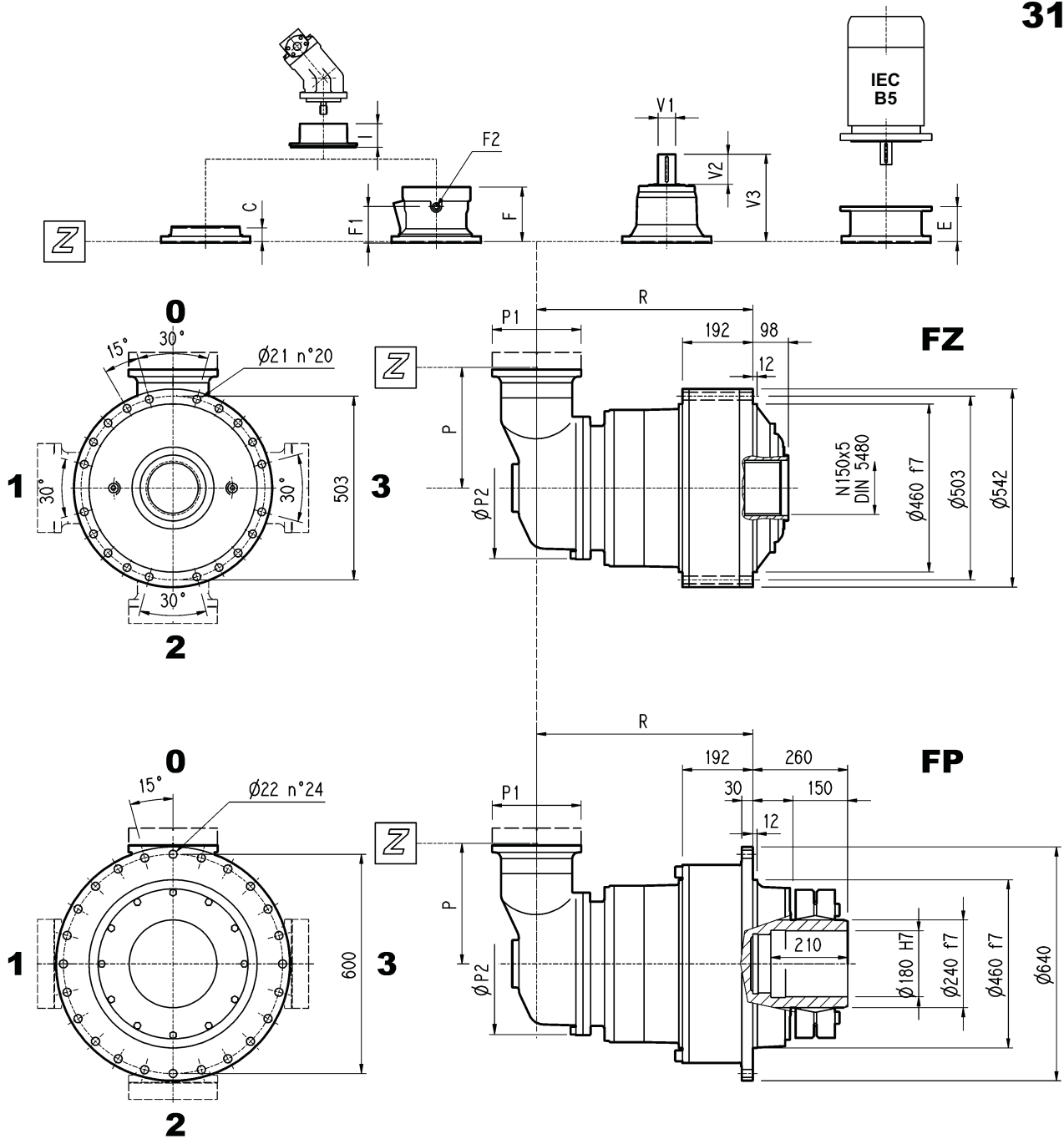

VERSIONE FP FP VERSION VERSION FP VERSION FP	COPPIA MAX. TRASMISSIBILE MAX. TRANSMISSIBLE TORQUE MAX. ÜBERTR. MOMENT COUPLE MAX. TRANSMISSIBLE	<b>126 000 Nm</b>
---	--	-------------------

	R				P	P1	P2	Kg				C	Entrata Input Antrieb Entrée	I	Entrata Input Antrieb Entrée				Kg	
	HZ HC	PC PZ	FZ	FP				HZ HC	PC PZ	FZ	FP				F	F1	F2	Tipo Type Typ Type		Entrata Input Antrieb Entrée
<b>315 R3 (B)</b>	611	890	611	611	345	262	400	590	720	500	550	45	B	191	195	147	1/4 G	6	B	28
<b>315 R3 (C)</b>	611	890	611	611	390	262	480	600	730	510	560	45	B		195	147	1/4 G	6	B	28
<b>315 R3 (A)</b>	611	890	611	611	330	245	390	565	695	475	525	37	A		145	95	1/4 G	5	A	16
<b>315 R4</b>	638	917	638	638	225	245	345	550	680	460	510	37	A		145	95	1/4 G	5	A	16

	V1	V2	V3	Kg	V1	V2	V3	Kg	E										
									IEC 71	IEC 80	IEC 90	IEC 100	IEC 112	IEC 132	IEC 160	IEC 180	IEC 200	IEC 225	IEC 250
<b>315 R3 (B)</b>	60	105	307	23												152	182	212	193
<b>315 R3 (C)</b>	60	105	307	23												152	182	212	193
<b>315 R3 (A)</b>	48	82	239	15										114	144	144	174		
<b>315 R4</b>	48	82	239	15										114	144	144	174		

**315L - 315R**

**HC**

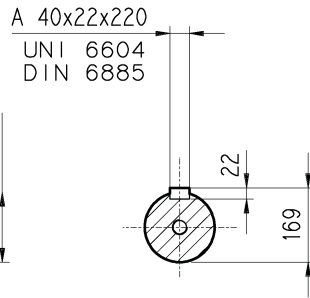
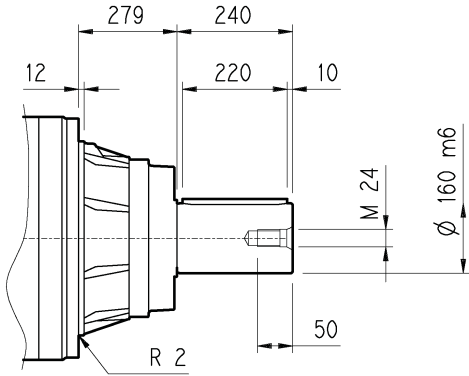

**PC**

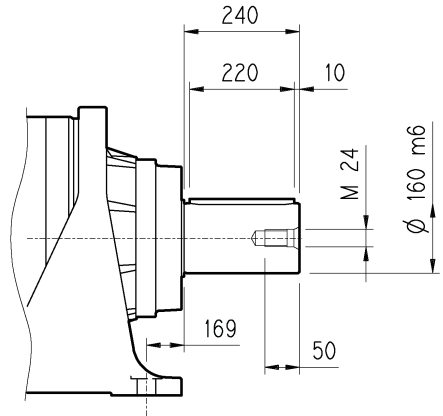

**HZ**

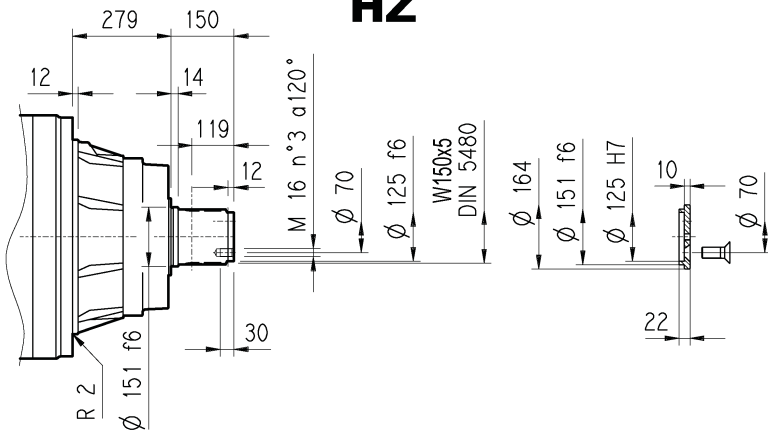

**FZ**

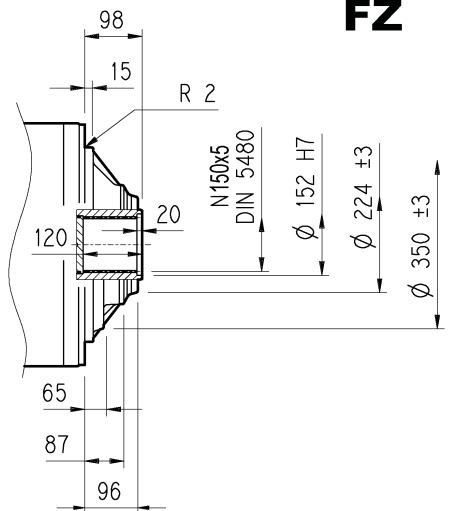

**FP**

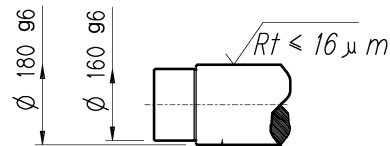
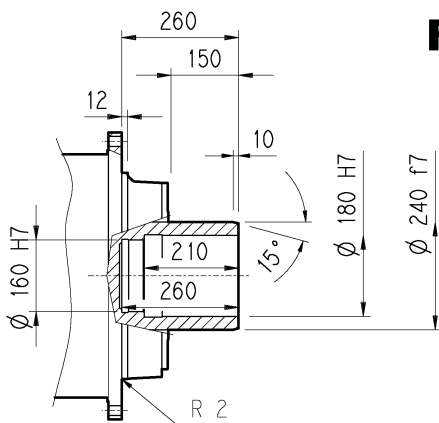

Acciaio / Steel  
Stahl / Acier  
 $R \geq 600 \text{ N/mm}^2$

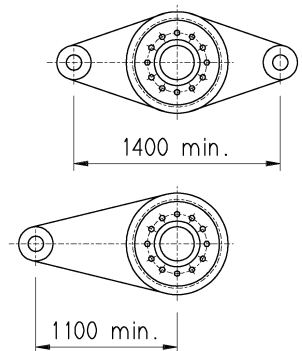

VERSIONE FP	COPPIA MAX. TRASMISSIBILE	<b>126 000</b> <b>Nm</b>
FP VERSION	MAX. TRANSMISSIBLE TORQUE	
VERSION FP	MAX. ÜBERTR. MOMENT	
VERSION FP	COUPLE MAX. TRASMISSIBILE	
VERSION FP		

Flangia / Flange  
Flansch / Brides

**315L - 315R**

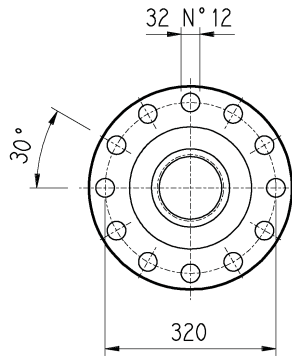
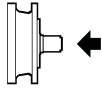

Materiale : Acciaio C40  
Material : Steel C40  
Material : Stahl C40  
Màterial : Acier C40

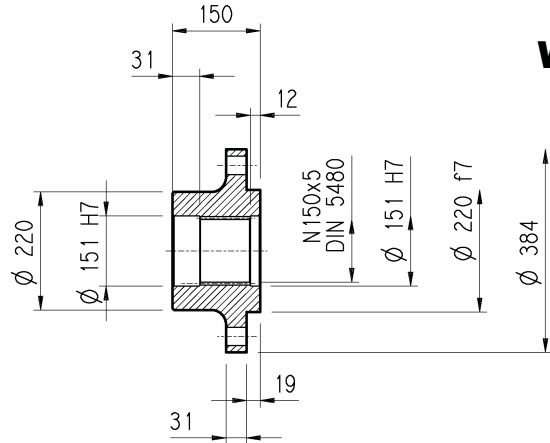

**WOA**

Pignoni per rotazione / Output pinions  
Ritzel / Pignons

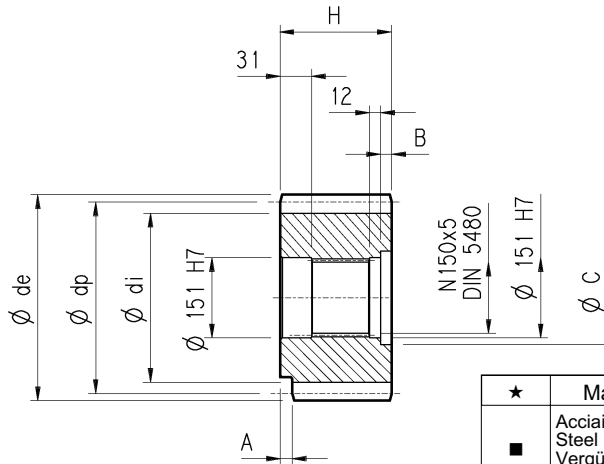
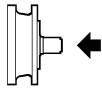

**P...**

	m	z	x	dp	di	de	H	A	B	C	★
PRG1	18	16	0.500	288	261	342	160	0	10	166	□
PRG2	18	16	0.617	288	271	339	150	30	0	0	■

★	Materiale/Material/Material/Màterial
■	Acciaio 39NiCrMo3 Bonificato Steel 39NiCrMo3 hardened and tempered Vergüteter Stahl 39NiCrMo3 Acier bonifié 39NiCrMo3
□	Acciaio 18NiCrMo5 Cementato e temprato Steel 18NiCrMo5 Case hardened Einsatzstahl 18NiCrMo5 Einsatzgehärtet Acier cementé et tempré 18NiCrMo5

Manicotti lisci / Sleeve couplings  
Naben / Manchons lisses a cannelure interieure

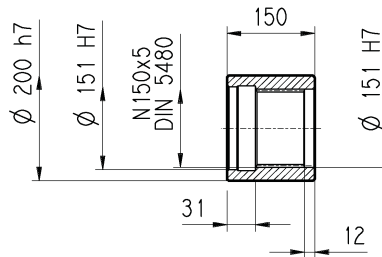
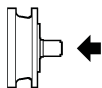

**MOA**

Materiale : Acciaio 16CrNi4  
Material : Steel 16CrNi4  
Material : Stahl 16CrNi4  
Màterial : Acier 16CrNi4

Barre scanalate / Splined bars  
Vielkeilwellen / Barre cannelée

**B0A**

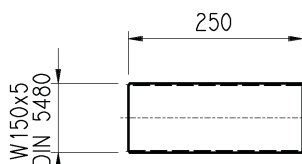
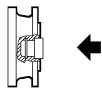

Mat. acciaio 18NiCrMo5 UNI 5331 da cementare e temprare 50-55 HRC  
Case hardening steel 18NiCrMo5 UNI 5331  
must be case hardened 50-55 HRC  
Material: Einsatzstahl 18NiCrMo5 UNI 5331  
muss einsatzgehärtet werden 50-55 HRC  
Acier 18 NiCrMo5 UNI 5331 doit être cémenté trempé 50-55 HRC

Giunto ad attrito / Shrink disc  
Schrumpfscheibe / Frette de serrage

**G0A**

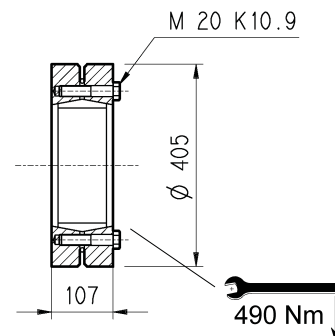
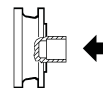



# 315L - 315R

Alberi veloci / Input shaft  
Antriebswellen / Arbres d'entrée

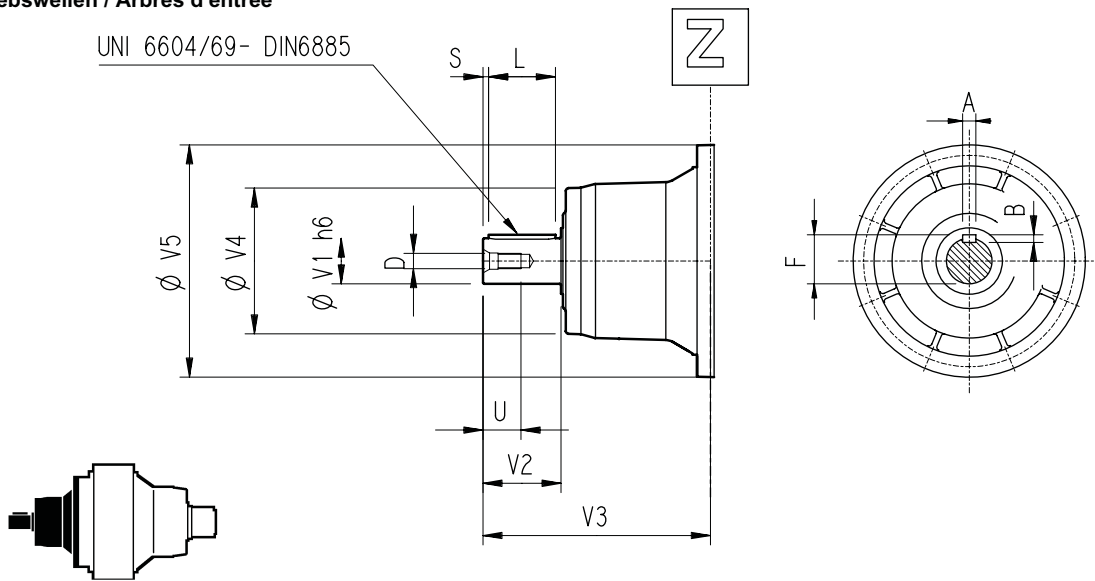

	CODE	V1	V2	V3	V4	V5	A	B	F	L	S	D	U
315 L2	V11B	80	130	348	200	428	22	14	85	110	10	M16	36
315 L3	V07B	80	130	315	200	345	22	14	85	110	10	M16	36
	V07A	60	105	313	155	345	18	11	64	90	7.5	M16	36
315 L4	V05B	48	82	239	155	245	14	9	51.5	70	6	M16	36
315 R3 (A)-R4	V05B	48	82	239	155	245	14	9	51.5	70	6	M16	36
315 R3 (B) (C)	V06B	60	105	307	155	292	18	11	64	90	7.5	M16	36

Dimensioni d'entrata senza predisposizione motore  
Input dimension without motor adaptor  
Maße für den Antrieb ohne Motoradapter  
Dimensions d'entrée sans prédisposition moteur

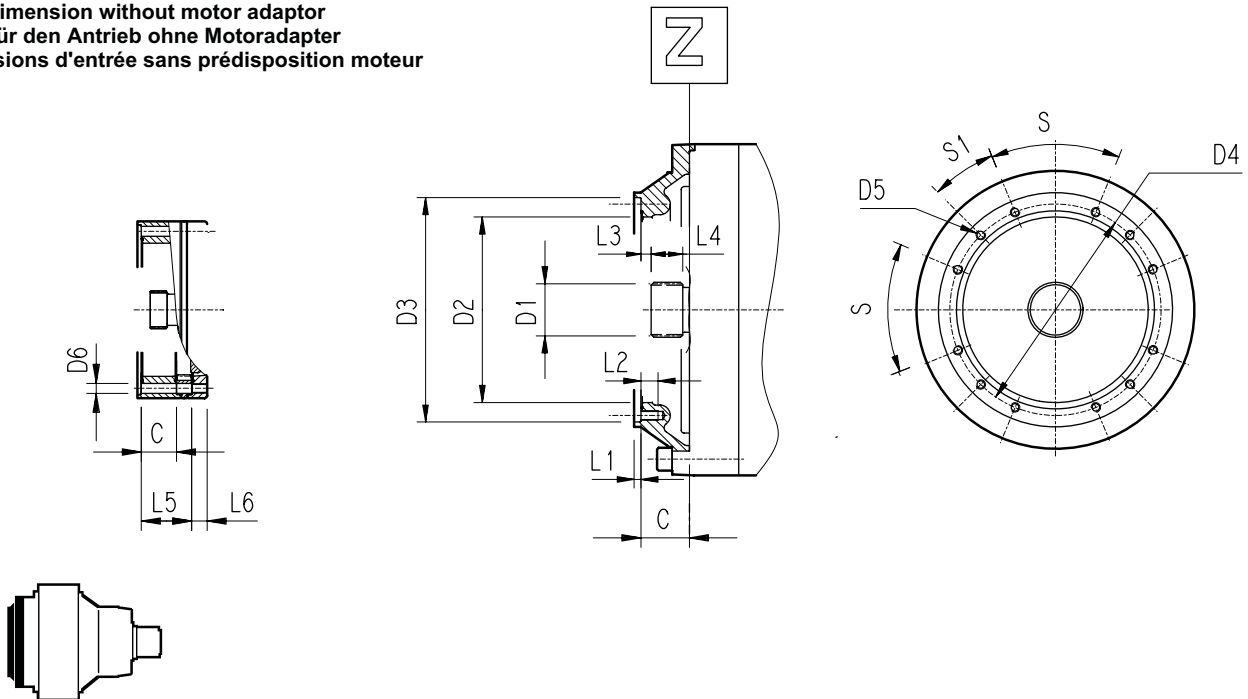

	C	D1	D2	D3	D4	D5	D6	L1	L2	L3	L4	L5	L6	S	S1	Entrata Input Antrieb Entrée
315 L1	116	100x94 DIN 5482	340	412 H7	390	M16 n°18	/	7	30	8	55	/	/	20°	20°	E
315 L2	81	80x74 DIN 5482	270	335 H7	314	M16 n°8	/	5	30	8.5	40	/	/	60°	30°	D
315 L3	51	58x53 DIN 5482	195	236 H7	222	M10 n°12	/	4	18	11	22	/	/	45°	22.5°	B
315 L4	37	40x36 DIN 5482	140	178 H7	165	M10 n°8	0	4	18	9	18	0	0	45°	45°	A
315 R2-R3 (A)-R4	37	40x36 DIN 5482	140	178 H7	165	M10 n°8	11	4	18	9	18	0	0	45°	45°	A
315 R3 (B) (C)	45	58x53 DIN 5482	195	236 H7	222	M10 n°12	/	4	18	11	22	/	/	45°	22.5°	B

### 315L - 315R

Carichi radiali ed assiali ammissibili sull'albero lento per un valore di  $Fh_2 : n_2 \cdot h = 10\ 000$

Permissible radial and axial loads on output shaft with  $Fh_2 : n_2 \cdot h = 10\ 000$

An der Ausgangswelle zulässige Radiallasten und Axialkräfte für einen Wert von  $Fh_2 : n_2 \cdot h = 10\ 000$

Charges radiales et axiales admises sur l'arbre lent pour une valeur de  $Fh_2 : n_2 \cdot h = 10\ 000$

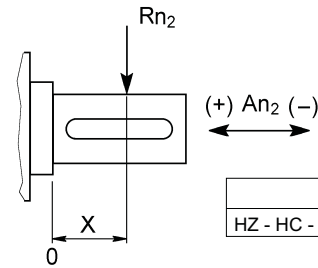
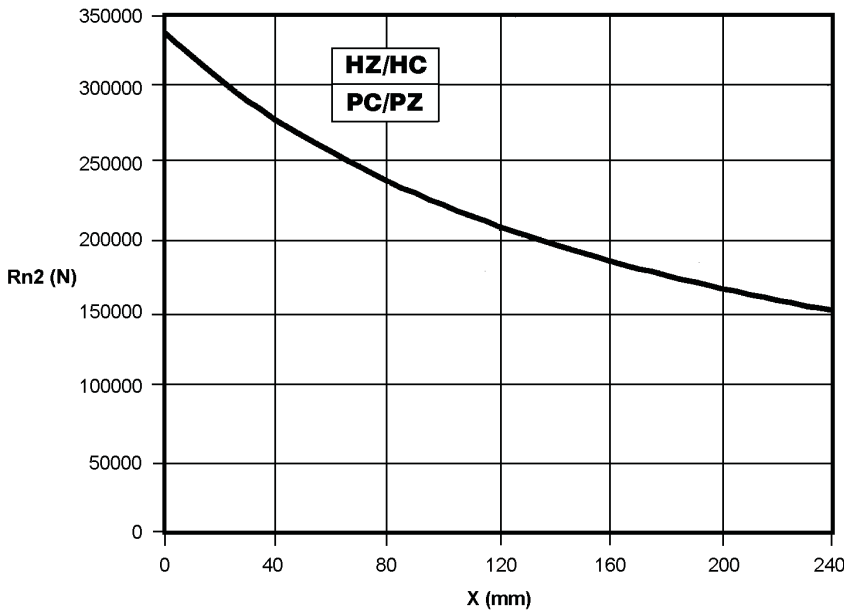

	An2 (+)	An2 (-)
HZ - HC - PC - PZ	280 000	210 000

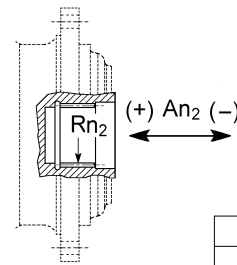

	Rn2	An2 (+/-)
FZ	90 000	90 000

Fattore $fh_2$ correttivo per carichi sugli alberi Load corrective factor $fh_2$ on shafts Korrektionsfaktor $fh_2$ für wellenbelastungen Facteur de correction $fh_2$ pour charges sur les arbres	$Fh_2 = n_2 \cdot h$						
		10 000	25 000	50 000	100 000	500 000	1 000 000
$fh_2$	FZ	1	0.74	0.58	0.46	0.27	0.21
	HZ - HC - PC - PZ	1	0.76	0.61	0.50	0.31	0.25

Carichi radiali ammissibili sull'albero veloce per un valore di  $Fh_1 : n_1 \cdot h = 250\ 000$

Permissible radial loads on input shaft with  $Fh_1 : n_1 \cdot h = 250\ 000$

An der Antriebswelle zulässige Radiallasten für einen Wert von  $Fh_1 : n_1 \cdot h = 250\ 000$

Charges radiales admises sur l'arbre d'entrée pour une valeur de  $Fh_1 : n_1 \cdot h = 250\ 000$

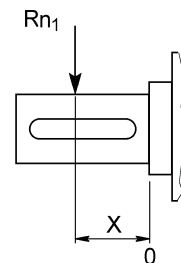
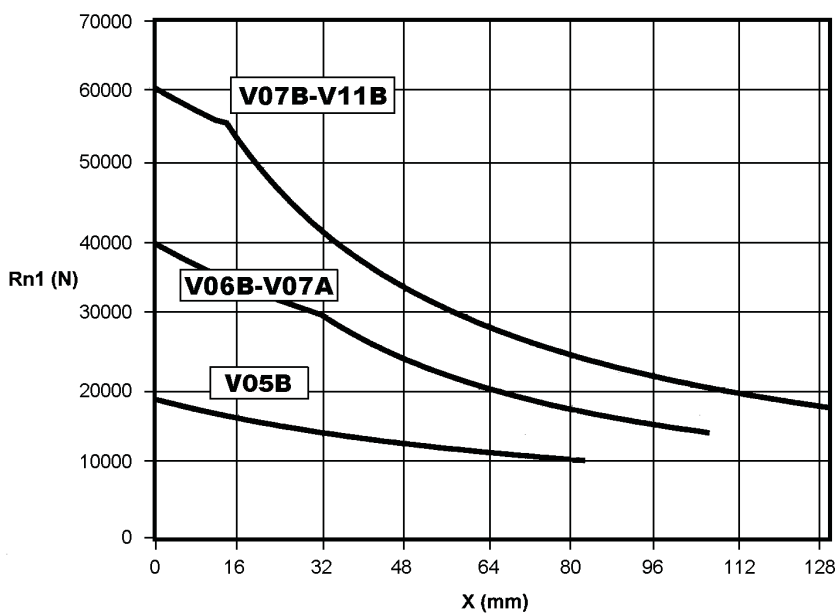

Fattore $fh_1$ correttivo per carichi sugli alberi Load corrective factor $fh_1$ on shafts Korrektionsfaktor $fh_1$ für wellenbelastungen Facteur de correction $fh_1$ pour charges sur les arbres	$Fh_1 = n_1 \cdot h$						
		250 000	500 000	1 000 000	2 000 000	5 000 000	10 000 000
$fh_1$	1	0.79	0.63	0.50	0.37	0.29	