



303L



M₂ = 2500 Nm

	i	M _{n2} [Nm]						P ₁	P _t	n ₁	n _{1max}	M _b	
		n ₂ ·h	n ₂ ·h	n ₂ ·h	n ₂ ·h	n ₂ ·h	n ₂ ·h						
	1:	10 000	25 000	50 000	100 000	500 000	1 000 000						
L1	3.60	2 300	2 200	2 150	2 100	2 100	1 750	40	11	1 800	3 800	800	5G
	4.25	2 900	2 750	2 650	2 600	2 150	1 750	40	11	1 800	3 800	800	5G
	5.33	2 850	2 450	2 200	2 200	2 100	1 700	40	11	1 800	3 800	630	5E
	6.20	2 300	2 000	1 800	1 800	1 750	1 400	40	11	1 800	3 800	500	5C
	7.50	2 000	1 750	1 650	1 650	1 650	1 500	36	11	1 800	3 800	400	5B
L2	12.5	2 300	2 200	2 150	2 100	1 850	1 500	20	9	2 000	4 000	260	4F
	15.3	2 300	2 200	2 150	2 100	1 800	1 450	20	9	2 000	4 000	260	4F
	18.1	2 900	2 750	2 650	2 600	2 000	1 650	20	9	2 000	4 000	260	4F
	20.8	2 300	2 200	2 150	2 100	1 700	1 400	17.0	9	2 000	4 000	160	4D
	22.7	2 850	2 450	2 200	2 200	2 100	1 700	16.2	9	2 000	4 000	160	4D
	24.5	2 750	2 700	2 650	2 600	1 900	1 550	17.8	9	2 000	4 000	160	4D
	26.4	2 300	2 000	1 800	1 800	1 750	1 400	11.4	9	2 000	4 000	160	4D
	30.8	2 850	2 450	2 200	2 200	2 100	1 700	12.0	9	2 000	4 000	160	4D
	35.8	2 300	2 000	1 800	1 800	1 750	1 400	8.5	9	2 000	4 000	100	4B
	38.4	2 850	2 450	2 200	2 200	2 000	1 600	10.0	9	2 000	4 000	100	4B
	44.6	2 300	2 000	1 800	1 800	1 750	1 400	7.0	9	2 000	4 000	100	4B
	54.0	2 000	1 750	1 650	1 650	1 650	1 500	5.3	7.5	2 000	4 000	50	4A
L3	43.6	2 300	2 200	2 150	2 100	1 900	1 500	8.6	7.5	2 000	4 000	100	4B
	53.4	2 300	2 200	2 150	2 100	1 800	1 450	7.1	7.5	2 000	4 000	100	4B
	63.1	2 886	2 700	2 650	2 600	2 100	1 700	7.3	7.5	2 000	4 000	100	4B
	72.3	2 300	2 200	2 150	2 100	1 900	1 500	5.3	7.5	2 000	4 000	50	4A
	77.2	2 900	2 750	2 650	2 600	2 000	1 650	6.2	7.5	2 000	4 000	50	4A
	90.2	2 300	2 200	2 150	2 100	1 900	1 500	4.3	7.5	2 000	4 000	50	4A
	105	2 900	2 750	2 650	2 600	2 000	1 650	4.7	7.5	2 000	4 000	50	4A
	113	2 300	2 000	1 800	1 800	1 750	1 400	3.4	7.5	2 000	4 000	50	4A
	124	2 300	2 000	1 800	1 800	1 750	1 400	3.1	7.5	2 000	4 000	50	4A
	141	2 750	2 700	2 650	2 600	1 900	1 550	3.3	7.5	2 000	4 000	50	4A
	152	2 300	2 000	1 800	1 800	1 750	1 400	2.6	7.5	2 000	4 000	50	4A
	164	2 850	2 450	2 200	2 200	2 100	1 700	3.0	7.5	2 000	4 000	50	4A
	178	2 850	2 450	2 200	2 200	2 100	1 700	2.8	7.5	2 000	4 000	50	4A
	190	2 300	2 000	1 800	1 800	1 750	1 400	2.2	7.5	2 000	4 000	50	4A
	220	2 250	2 200	2 250	2 250	1 700	1 400	1.9	7.5	2 000	4 000	50	4A
	258	2 300	2 000	1 800	1 800	1 750	1 400	1.7	7.5	2 000	4 000	50	4A
	276	2 850	2 450	2 200	2 200	2 000	1 600	1.9	7.5	2 000	4 000	50	4A
312	2 000	1 750	1 650	1 650	1 650	1 500	1.2	7.5	2 000	4 000	50	4A	
389	2 000	1 750	1 650	1 650	1 650	1 500	1.0	7.5	2 000	4 000	50	4A	
L4	413	2 850	2 450	2 200	2 200	2 100	1 700	2.0	6	2 000	4 000	50	4A
	446	2 900	2 750	2 650	2 600	2 000	1 650	2.0	6	2 000	4 000	50	4A
	492	2 750	2 700	2 650	2 600	1 900	1 550	1.6	6	2 000	4 000	50	4A
	556	2 900	2 750	2 650	2 600	2 000	1 650	1.6	6	2 000	4 000	50	4A
	649	2 300	2 200	2 150	2 100	1 850	1 500	1.1	6	2 000	4 000	50	4A
	718	2 300	2 000	1 800	1 800	1 750	1 400	1.1	6	2 000	4 000	50	4A
	816	2 750	2 700	2 650	2 600	1 900	1 550	1.1	6	2 000	4 000	50	4A
	896	2 300	2 000	1 800	1 800	1 750	1 400	0.94	6	2 000	4 000	50	4A
	1 018	2 750	2 700	2 650	2 600	1 900	1 550	0.91	6	2 000	4 000	50	4A
	1 098	2 300	2 000	1 800	1 800	1 750	1 400	0.79	6	2 000	4 000	50	4A
	1 278	2 850	2 450	2 200	2 200	2 100	1 700	0.74	6	2 000	4 000	50	4A
	1 370	2 300	2 000	1 800	1 800	1 750	1 400	0.66	6	2 000	4 000	50	4A
	1 586	2 250	2 250	2 250	2 250	1 700	1 350	0.58	6	2 000	4 000	50	4A
	1 854	2 300	2 000	1 800	1 800	1 750	1 400	0.51	6	2 000	4 000	50	4A
	1 991	2 850	2 450	2 200	2 200	2 000	1 600	0.48	6	2 000	4 000	50	4A
2 243	2 000	1 750	1 650	1 650	1 650	1 500	0.37	6	2 000	4 000	50	4A	
2 799	2 000	1 750	1 650	1 650	1 650	1 500	0.30	6	2 000	4 000	50	4A	

M_{2max} = 1.2 · M_{n2} (n₂ · h = 10 000)

M₂ = 2500 Nm

303R

	i	M _{n2} [Nm]						P ₁ [kW]	P _t [kW]	n ₁ [min ⁻¹]	n _{1max} [min ⁻¹]	M _b [Nm]	
		n ₂ ·h 10 000	n ₂ ·h 25 000	n ₂ ·h 50 000	n ₂ ·h 100 000	n ₂ ·h 500 000	n ₂ ·h 1 000 000						
R2	9.23	2 300	2 200	2 150	2 100	2 000	1 600	35	18	1 800	3 800	330	4H
	10.9	2 900	2 750	2 650	2 600	2 150	1 750	35	18	1 800	3 800	330	4H
	13.7	2 850	2 450	2 200	2 200	2 100	1 700	27	18	1 800	3 800	260	4F
	15.9	2 300	2 000	1 800	1 800	1 750	1 400	18.9	18	1 800	3 800	260	4F
	19.2	2 000	1 750	1 650	1 650	1 650	1 500	14.3	18	1 800	3 800	160	4D
R3	25.7	2 300	2 200	2 150	2 100	1 850	1 500	14.3	14	2 000	4 000	160	4D
	31.5	2 300	2 200	2 150	2 100	1 800	1 450	11.8	14	2 000	4 000	100	4B
	37.1	2 900	2 750	2 650	2 600	2 000	1 650	12.4	14	2 000	4 000	100	4B
	42.6	2 300	2 200	2 150	2 100	1 700	1 400	8.8	14	2 000	4 000	100	4B
	46.6	2 850	2 450	2 200	2 200	2 100	1 700	8.7	14	2 000	4 000	100	4B
	50.3	2 750	2 700	2 650	2 600	1 900	1 550	9.2	14	2 000	4 000	100	4B
	54.2	2 300	2 000	1 800	1 800	1 750	1 400	6.2	14	2 000	4 000	100	4B
	63.1	2 850	2 450	2 200	2 200	2 100	1 700	6.8	14	2 000	4 000	100	4B
	73.3	2 300	2 000	1 800	1 800	1 750	1 400	4.8	14	2 000	4 000	50	4A
	78.7	2 850	2 450	2 200	2 200	2 000	1 600	5.6	14	2 000	4 000	50	4A
	91.5	2 300	2 000	1 800	1 800	1 750	1 400	4.0	14	2 000	4 000	50	4A
	111	2 000	1 750	1 650	1 650	1 650	1 500	3.0	12	2 000	4 000	50	4A
R4	129	2 850	2 700	2 650	2 600	2 100	1 700	6.1	12	2 000	4 000	50	4A
	148	2 300	2 200	2 150	2 100	1 850	1 500	4.5	12	2 000	4 000	50	4A
	158	2 900	2 750	2 650	2 600	2 000	1 650	5.3	12	2 000	4 000	50	4A
	185	2 300	2 200	2 150	2 100	1 850	1 500	3.6	12	2 000	4 000	50	4A
	214	2 900	2 750	2 650	2 600	2 000	1 650	4.0	12	2 000	4 000	50	4A
	231	2 300	2 000	1 800	1 800	1 750	1 400	2.9	12	2 000	4 000	50	4A
	255	2 300	2 000	1 800	1 800	1 750	1 400	2.7	12	2 000	4 000	50	4A
	290	2 750	2 700	2 650	2 600	1 900	1 550	2.9	12	2 000	4 000	50	4A
	313	2 300	2 000	1 800	1 800	1 750	1 400	2.3	12	2 000	4 000	50	4A
	336	2 850	2 450	2 200	2 200	2 100	1 700	2.5	12	2 000	4 000	50	4A
	364	2 850	2 450	2 200	2 200	2 100	1 700	2.5	12	2 000	4 000	50	4A
	390	2 300	2 000	1 800	1 800	1 750	1 400	1.9	12	2 000	4 000	50	4A
	452	2 250	2 250	2 250	2 250	1 700	1 400	1.6	12	2 000	4 000	50	4A
	528	2 300	2 000	1 800	1 800	1 750	1 400	1.3	12	2 000	4 000	50	4A
	567	2 850	2 450	2 200	2 200	2 000	1 600	1.6	12	2 000	4 000	50	4A
	639	2 000	1 750	1 650	1 650	1 650	1 500	1.1	12	2 000	4 000	50	4A
797	2 000	1 750	1 650	1 650	1 650	1 500	0.88	12	2 000	4 000	50	4A	

M_{2max} = 1.2 · M_{n2} (n₂ · h = 10 000)

303L

		Motore idraulico / Hydraulic motor Hydraulikmotor/Moteur hydraulique							201			
		MG										
cm ³	50	80	100	125	160	200	250	M2	M3	M4		
	M1	M1	M1	M1	M1	M1	M1					
303L1	-	-	-	-	199	206	215	135	77	1/4G	20	
303L2	156	162	166	170	177	184	-	113	60	1/4G	14	

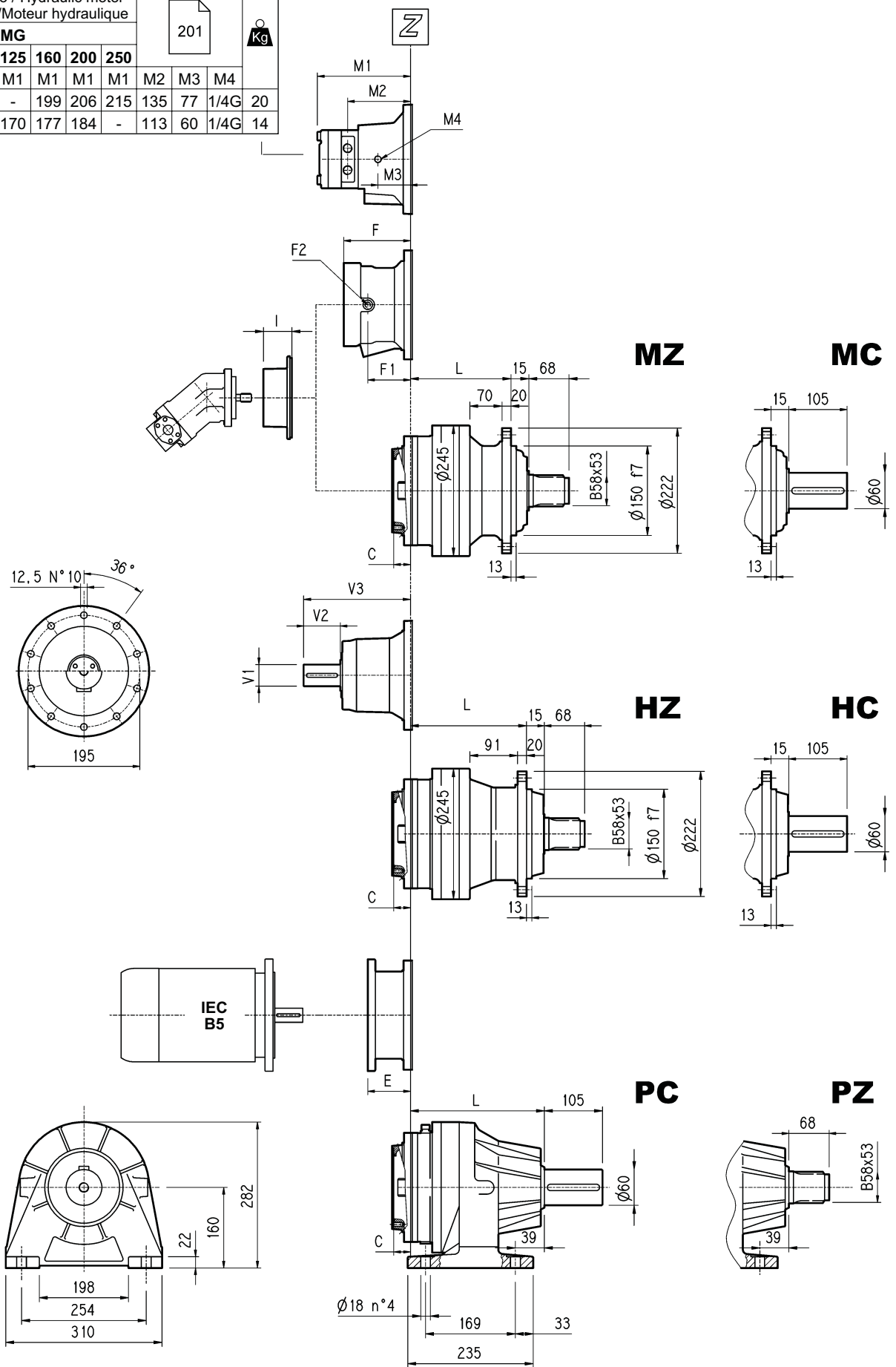

303L

		Motore idraulico / Hydraulic motor Hydraulikmotor/Moteur hydraulique						201			Kg
		MG									
cm³	50	80	100	125	160	200	250	M2	M3	M4	
	M1	M1	M1	M1	M1	M1	M1	M2	M3	M4	
303L1	-	-	-	-	199	206	215	135	77	1/4G	20
303L2	156	162	166	170	177	184	-	113	60	1/4G	14

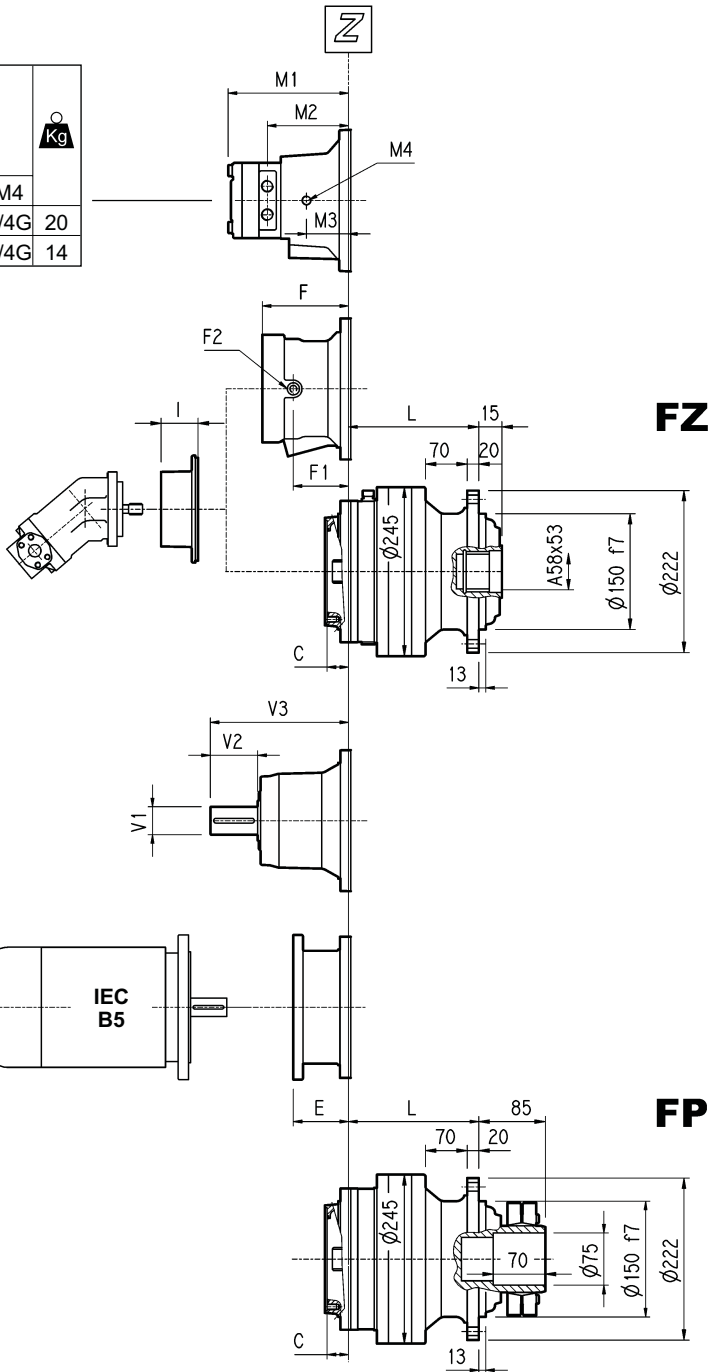
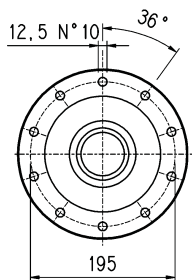
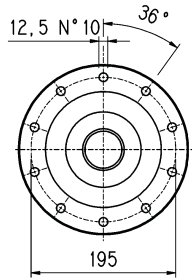

VERSIONE FP	COPPIA MAX. TRASMISSIBILE MAX. TRANSMISSIBLE TORQUE MAX. ÜBERTR. MOMENT COUPLE MAX. TRANSMISSIBLE	3 500 Nm
FP VERSION		
VERSION FP		
VERSION FP		

	L				Kg				C	Entrata Input Antrieb Entrée	I	F	F1	F2	Tipo Type Typ Type	Entrata Input Antrieb Entrée	Kg
	MZ	MC	FZ	FP	HZ	HC	PC	PZ									
303 L1	125	125	150	165	31	31	35	40	37	A	191	145	95	1/4 G	5	A	16
303 L2	178	178	203	218	35	35	39	44	37	A		105	65	1/4 G	4	A	10
303 L3	231	231	256	271	39	39	43	48	37	A		105	65	1/4 G	4	A	10
303 L4	284	284	309	324	43	43	47	52	37	A		105	65	1/4 G	4	A	10

	V1	V2	V3	Kg	V1	V2	V3	Kg	E												
									IEC 71	IEC 80	IEC 90	IEC 100	IEC 112	IEC 132	IEC 160	IEC 180	IEC 200				
303 L1	48	82	239	15																	
303 L2	24	36	137.5	6	38	58	158	7	65	84	84	94	94	114	144						
303 L3	24	36	137.5	6	38	58	158	7	65	84	84	94	94	114	144						
303 L4	24	36	137.5	6	38	58	158	7	65	84	84	94	94	114	144						

303R

		Motore idraulico / Hydraulic motor Hydraulikmotor/Moteur Hydraulique						201			Kg
		MG									
cm ³	50	80	100	125	160	200	250	M1	M2	M3	M4
303R2	156	162	166	170	177	184	-	113	60	1/4G	14

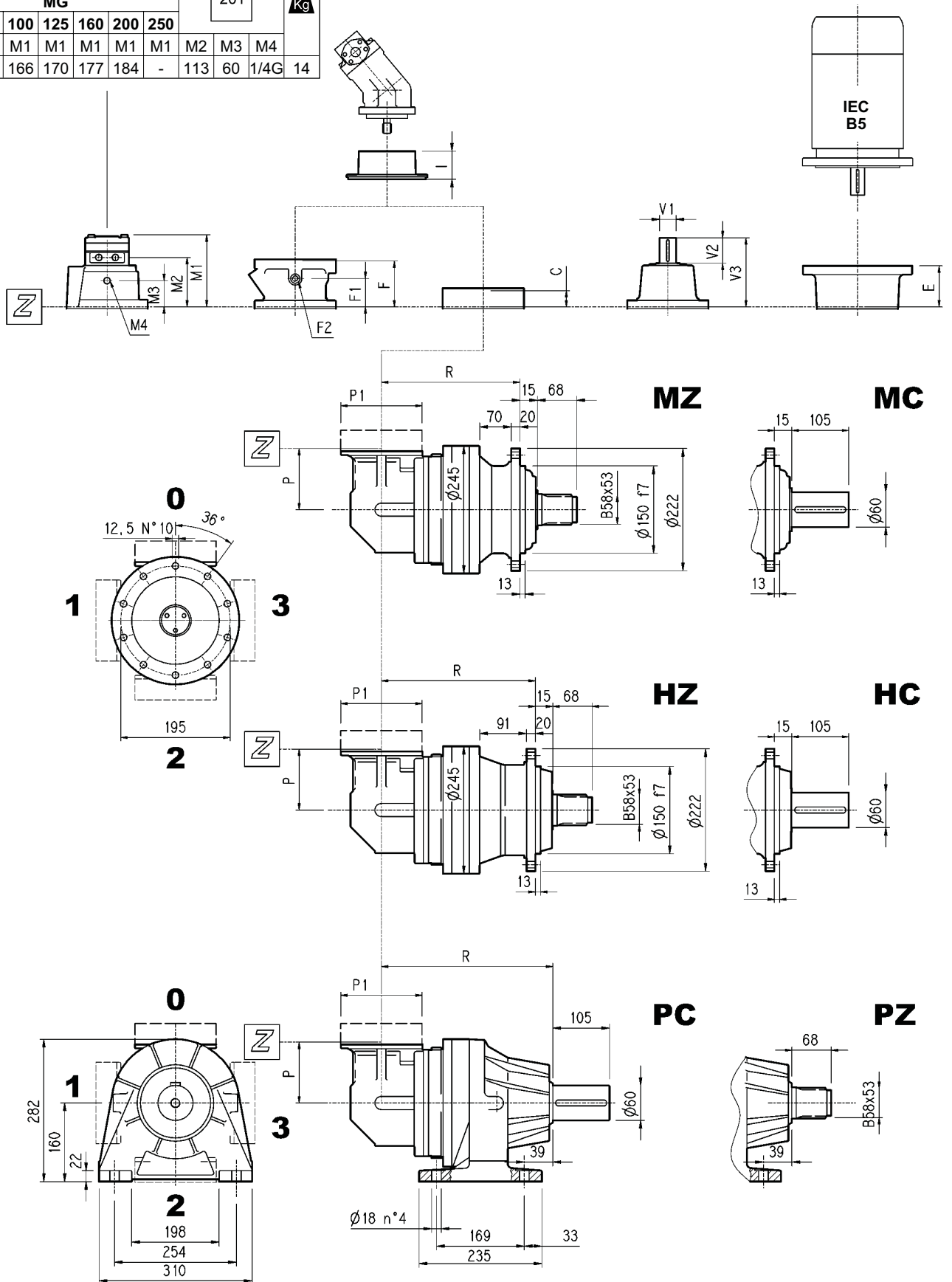

303R

		Motore idraulico / Hydraulic motor Hydraulikmotor/Moteur hydraulique							201			
		MG										
cm³	50	80	100	125	160	200	250	M2	M3	M4		
	M1	M1	M1	M1	M1	M1	M1					
303R2	156	162	166	170	177	184	-	113	60	1/4G	14	

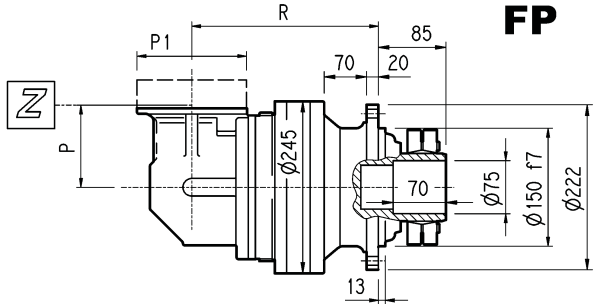
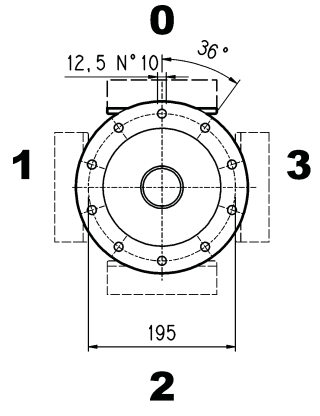
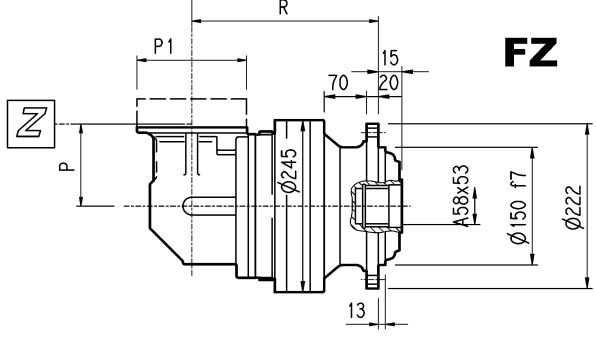
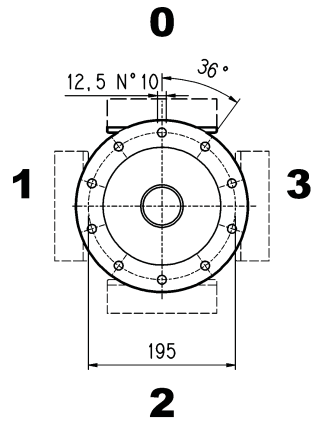
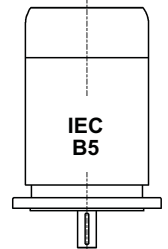
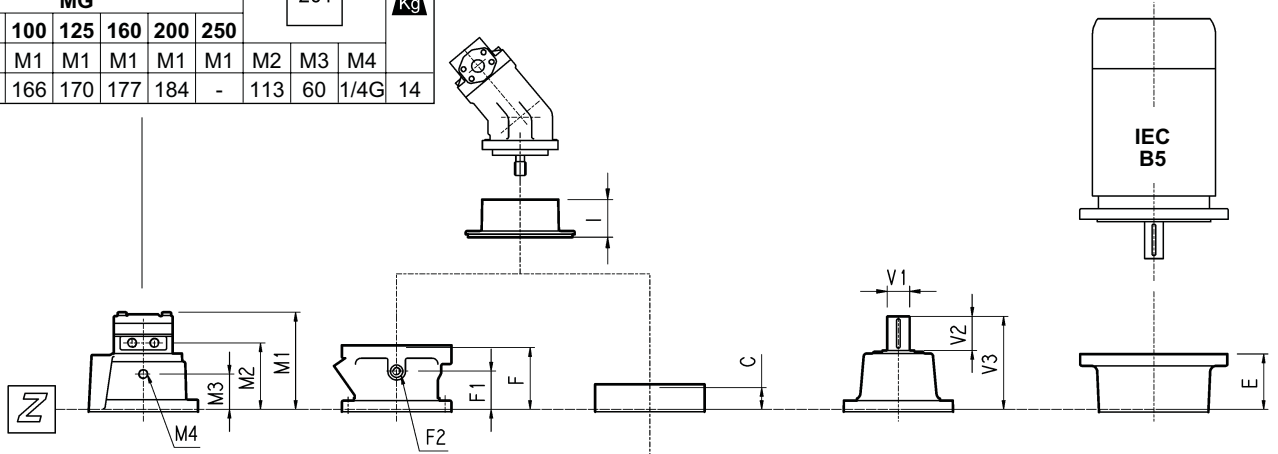

VERSIONE FP	COPPIA MAX. TRASMISSIBILE MAX. TRANSMISSIBLE TORQUE MAX. ÜBERTR. MOMENT COUPLE MAX. TRANSMISSIBLE	3 500 Nm
FP VERSION		
VERSION FP		
VERSION FP		

	R				P	P1					C	Entrata Input Antrieb Entrée	I	F	F1	F2	Tipo Type Typ Type	Entrata Input Antrieb Entrée	
	MZ MC	FZ FP	HZ HC	PC PZ			MZ MC	FZ FP	HZ HC	PC PZ									
303 R2	217	217	242	257	140	186	51	51	55	60	37	A		105	65	1/4 G	4	A	10
303 R3	270	270	295	310	122	186	49	49	53	58	37	A		105	65	1/4 G	4	A	10
303 R4	323	323	348	363	122	186	53	53	57	62	37	A		105	65	1/4 G	4	A	10

	V1	V2	V3		V1	V2	V3		E									
									IEC 71	IEC 80	IEC 90	IEC 100	IEC 112	IEC 132				
303 R2	24	36	137.5	6	38	58	158	7	65	84	84	94	94	114				
303 R3	24	36	137.5	6	38	58	158	7	65	84	84	94	94	114				
	24	36	137.5	6	38	58	158	7	65	84	84	94	94	114				

303L - 303R

MC-HC

PC

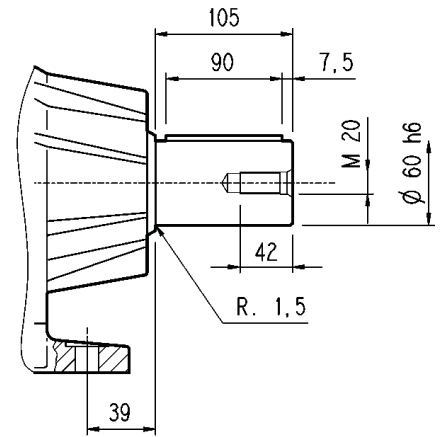
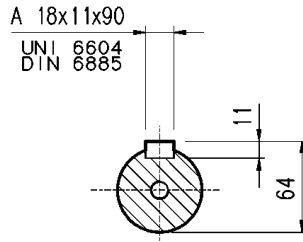
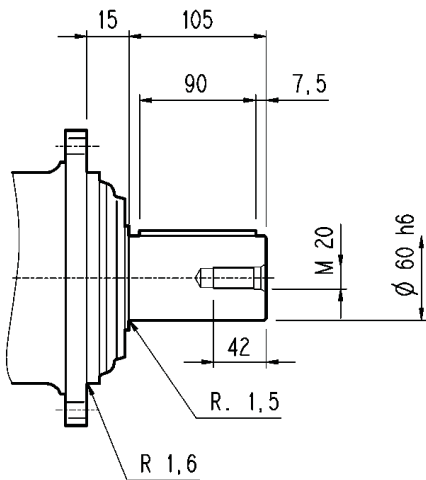

MZ-HZ

FZ

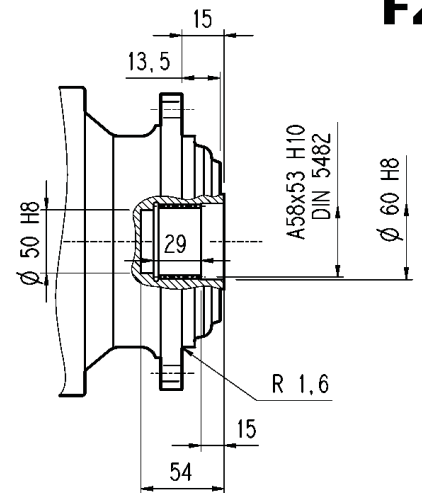
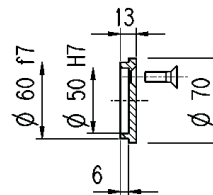
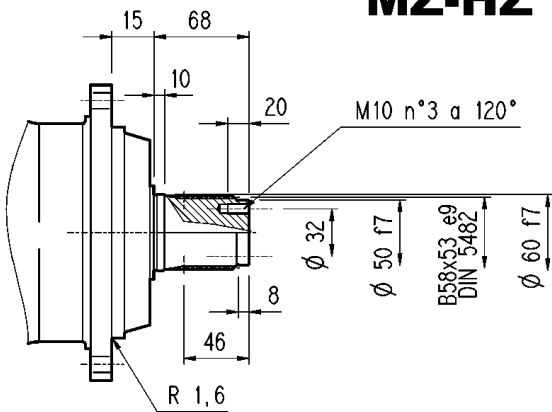

FP

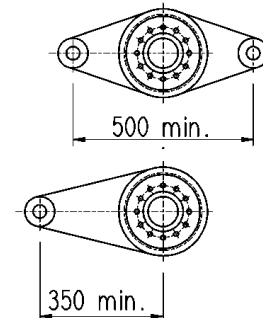
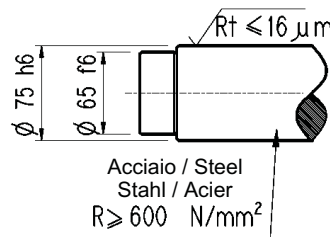
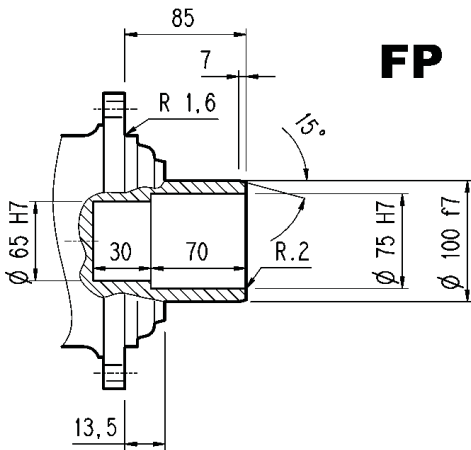

VERSIONE FP	COPPIA MAX. TRASMISSIBILE	3 500 Nm
FP VERSION	MAX. TRANSMISSIBLE TORQUE	
VERSION FP	MAX. ÜBERTR. MOMENT	
VERSION FP	COUPLE MAX. TRANSMISSIBLE	

Flangia / Flange
Flansch / Brides

303L - 303R

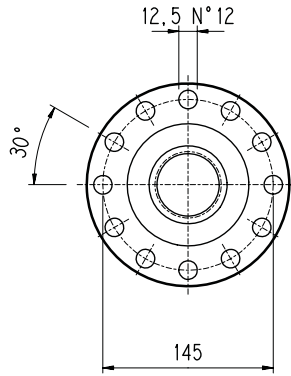
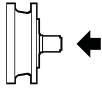

Materiale : Acciaio C40
Material : Steel C40
Material : Stahl C40
Màterial : Acier C40

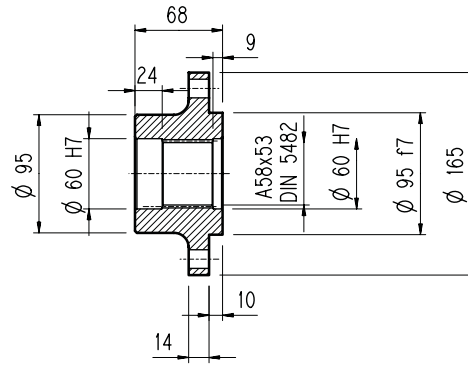

WOA

Pignoni per rotazione / Output pinions
Ritzel / Pignons

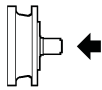

Codice Code	m	z	x	dp	di	de	H	A	B	C	★
PCL1	5	19	0	95	82	104	77	12	9	72	■
PCL2	5	19	0	95	82	104	68	0	0	0	■
PCM	5	20	0	100	87.5	110	68	18	0	0	□
PCP	5	22	0	110	97.5	120	68	18	0	0	□
PDE	6	14	0.500	84	75	99.6	68	0	0	0	■
PDI	6	18	0.500	108	99	123.6	68	0	0	0	■
PDM	6	20	0.833	120	115	140	68	0	0	0	■
PFD	8	13	0.675	104	95	127.6	68	0	0	0	□
PFE1	8	14	0	112	92	126	68	0	0	0	□
PFE2	8	14	0	112	92	126	80	0	12	72	□
PFF	8	15	0	120	100	136	68	0	0	0	■
PFP	8	22	0	176	156	190	77	12	10	71	■
PHG	10	16	0.500	160	145	188	75	0	7	72	■

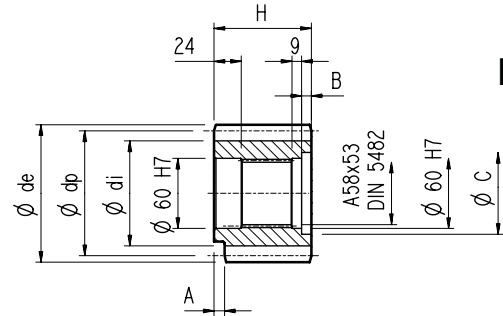

P...

★	Materiale/Material/Material/Màterial
■	Acciaio 39NiCrMo3 Bonificato Steel 39NiCrMo3 hardened and tempered Vergüteter Stahl 39NiCrMo3 Acier bonifié 39NiCrMo3
□	Acciaio 18NiCrMo5 Cementato e temprato Steel 18NiCrMo5 Case hardened Einsatzstahl 18NiCrMo5 Einsatzgehärtet Acier cementé et tempré 18NiCrMo5

Manicotti lisci / Sleeve couplings
Naben / Manchons lisses a cannelure interieure

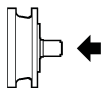

Materiale : Acciaio 16CrNi4
Material : Steel 16CrNi4
Material : Stahl 16CrNi4
Màterial : Acier 16CrNi4

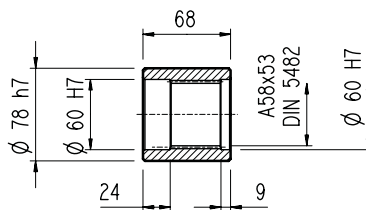

MOA

Barre scanalate / Splined bars
Vielkeilwellen / Barre cannelée

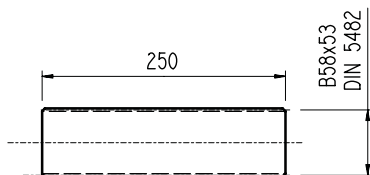
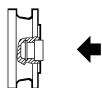

B0A

Mat. acciaio 18NiCrMo5 UNI 5331 da cementare e temprare 50-55 HRC
Case hardening steel 18NiCrMo5 UNI 5331
must be case hardened 50-55 HRC
Material: Einsatzstahl 18NiCrMo5 UNI 5331
muss einsatzgehärtet werden 50-55 HRC
Acier 18 NiCrMo5 UNI 5331 doit être cémenté trempé 50-55 HRC

Giunto ad attrito / Shrink disc
Schrumpfscheibe / Frette de serrage

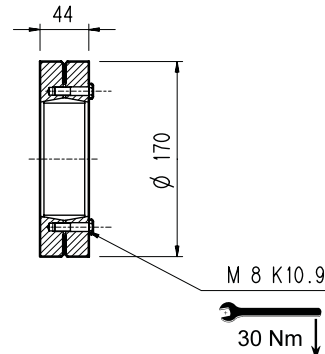

G0A

303L - 303R

Alberi veloci / Input shaft
Antriebswellen / Arbres d'entrée

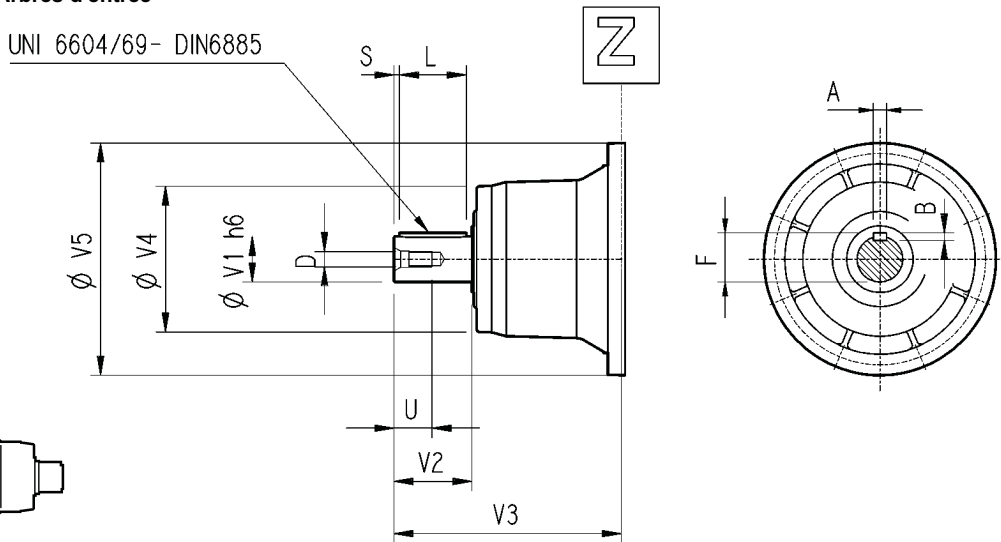

	CODE	V1	V2	V3	V4	V5	A	B	F	L	S	D	U
303 L1	V05B	48	82	239	155	245	14	9	51.5	70	6	M16	36
303 L2	V01A	24	36	137.5	120	186	8	7	27	30	3	M8	19
	V01B	38	58	158	120	186	10	8	41	50	4	M12	28
303 L3	V01A	24	36	137.5	120	186	8	7	27	30	3	M8	19
	V01B	38	58	158	120	186	10	8	41	50	4	M12	28
303 L4	V01A	24	36	137.5	120	186	8	7	27	30	3	M8	19
	V01B	38	58	158	120	186	10	8	41	50	4	M12	28
303 R2-R3-R4	V01A	24	36	137.5	120	186	8	7	27	30	3	M8	19
	V01B	38	58	158	120	186	10	8	41	50	4	M12	28

Dimensioni d'entrata senza predisposizione motore
Input dimension without motor adaptor
Maße für den Antrieb ohne Motoradapter
Dimensions d'entrée sans prédisposition moteur

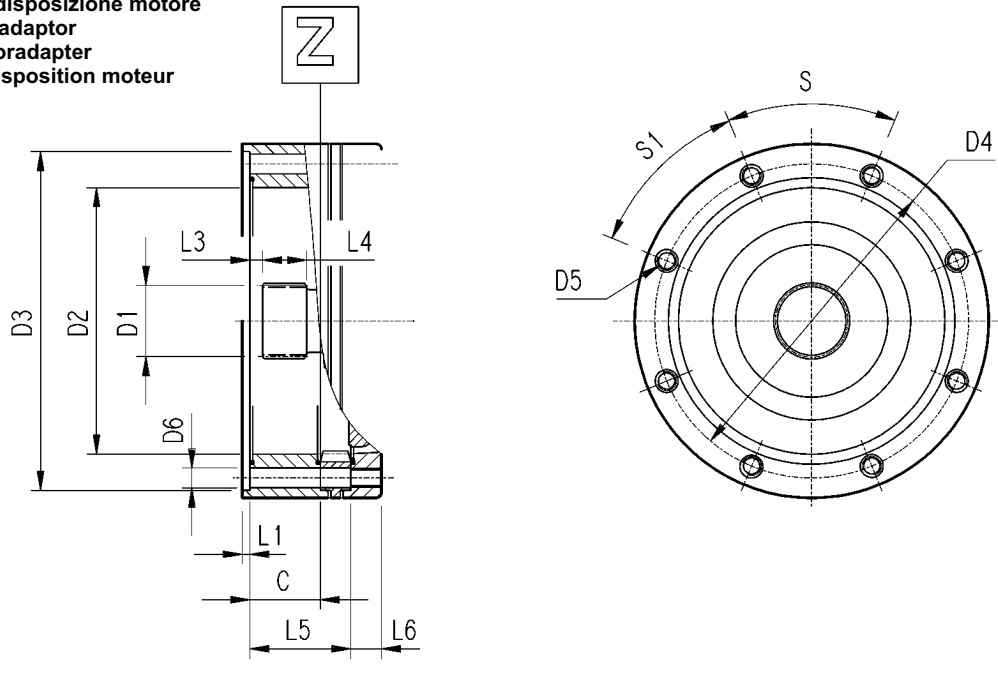

	C	D1	D2	D3	D4	D5	D6	L1	L2	L3	L4	L5	L6	S	S1	Entrata Input Antrieb Entrée
303 L1	37	40x36 DIN5482	140	178 H7	165	M10 n°8	11	4	18	9	18	0	0	45°	45°	A
303 L2	37	40x36 DIN5482	140	178 H7	165	M10 n°8	11	4	/	9	18	53	18	45°	45°	A
303 L3	37	40x36 DIN5482	140	178 H7	165	M10 n°8	11	4	/	9	18	106	18	45°	45°	A
303 L4	37	40x36 DIN5482	140	178 H7	165	M10 n°8	11	4	/	9	18	159	18	45°	45°	A
303 R2-R3-R4	37	40x36 DIN5482	140	178 H7	165	M10 n°8	11	4	/	9	18	37	18	45°	45°	A

303L - 303R

Carichi radiali ed assiali ammissibili sull'albero lento per un valore di $F_{h2} : n_2 \cdot h = 10\ 000$

Permissible radial and axial loads on output shaft with $F_{h2} : n_2 \cdot h = 10\ 000$

An der Ausgangswelle zulässige Radiallasten und Axialkräfte für einen Wert von $F_{h2} : n_2 \cdot h = 10\ 000$

Charges radiales et axiales admises sur l'arbre lent pour une valeur de $F_{h2} : n_2 \cdot h = 10\ 000$

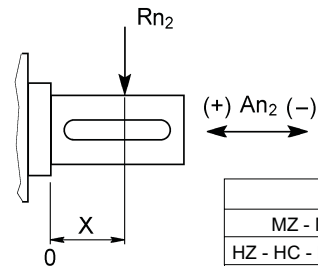
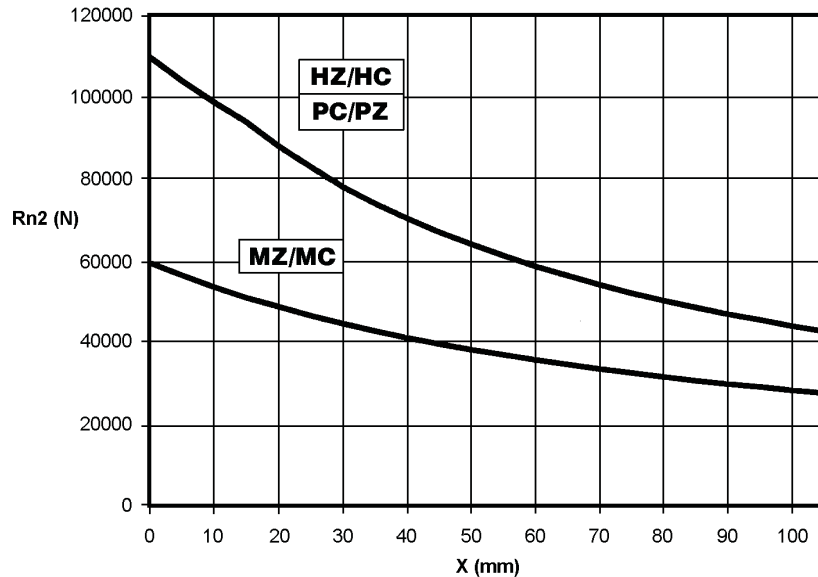

	An2 (+)	An2 (-)
MZ - MC	55 000	44 000
HZ - HC - PC - PZ	55 000	44 000

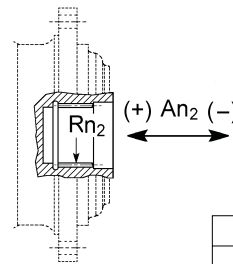

	Rn2	An2 (+/-)
FZ	24 000	25 000

Fattore fh2 correttivo per carichi sugli alberi Load corrective factor fh2 on shafts Korrektionsfaktor fh2 für wellenbelastungen Facteur de correction fh2 pour charges sur les arbres	$F_{h2} = n_2 \cdot h$						
		10 000	25 000	50 000	100 000	500 000	1 000 000
fh2	MZ - MC - FZ	1	0.74	0.58	0.46	0.27	0.21
	HZ - HC - PC - PZ	1	0.76	0.61	0.50	0.31	0.25

Carichi radiali ammissibili sull'albero veloce per un valore di $F_{h1} : n_1 \cdot h = 250\ 000$

Permissible radial loads on input shaft with $F_{h1} : n_1 \cdot h = 250\ 000$

An der Antriebswelle zulässige Radiallasten für einen Wert von $F_{h1} : n_1 \cdot h = 250\ 000$

Charges radiales admises sur l'arbre d'entrée pour une valeur de $F_{h1} : n_1 \cdot h = 250\ 000$

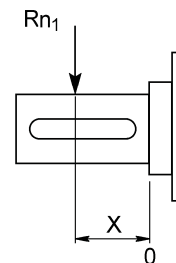
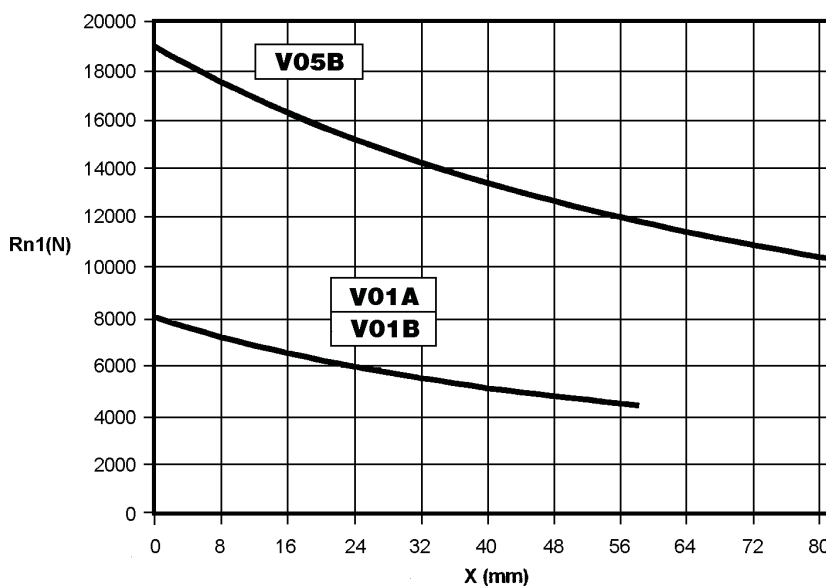

Fattore fh1 correttivo per carichi sugli alberi Load corrective factor fh1 on shafts Korrektionsfaktor fh1 für wellenbelastungen Facteur de correction fh1 pour charges sur les arbres	$F_{h1} = n_1 \cdot h$						
		250 000	500 000	1 000 000	2 000 000	5 000 000	10 000 000
fh1	1	0.79	0.63	0.50	0.37	0.29	